

# SAP System Cloning (Homogeneous System Copy) Solution on the IBM® TotalStorage® DS8300

## CONTENTS

Abstract	4
1. Introduction	5
2. Customer Requirements	6
3. Introduction to DS8000	6
4. DS8000 Architecture	8
5. Copy Services:	10
6. Installation Preparations and Lab Setup	12
7. SAP/Oracle Database Layout	13
8. Homogeneous System Copy Process	14
System Cloning Process Scenario	15
Appendix	23
9. Sample Cloning Scripts	23
Main Script	23
Prepare Script on Target host	24
Input Config File	25
Hardware used for the system cloning solution	26
Software used for the system cloning solution	26
Logs	27
Prepare phase log	27
FlashCopy phase log	28
Restore phase log	29
Clone phase log	31
Post Copy Phase log	34
10. Post cloning observations	35
References	36

## SAP System Cloning Solution using the IBM TotalStorage DS8300

The following terms are trademarks of International Business Machines Corporation in the United States, other countries, or both:

AIX®, DB2 Universal Database®, Enterprise Storage Server (ESS)®, FlashCopy®, IBM TotalStorage Server DS6000®, Tivoli®

The following terms are trademarks of SAP AG in Germany, in the United States, other countries, or both:

SAP®, SAP Logo®, mySAP.com®, R/3®, ABAP®, SSQJ®, Advanced Technology Group®, OSS®, SAP R/3 Note®

The following terms are trademarks of Oracle Corporation in the United States, other countries, or both:

ORACLE®

The information provided in this document is distributed "AS IS" basis without any warranty either express or implied. IBM AND SAP DISCLAIM ALL EXPRESS AND IMPLIED WARRANTIES WITH RESPECT TO SUCH INFORMATION, INCLUDING ANY WARRANTIES OF MERCHANTABILITY OR FITNESS FOR A PARTICULAR PURPOSE. The use of this information or the implementation of any of these techniques is a customer responsibility and depends on the customer's ability to evaluate and integrate them into their operating environment. While the information contained in this paper has been reviewed by IBM and SAP for accuracy, there is no guarantee that the same or similar results will be obtained elsewhere. Customers attempting to adapt these techniques to their own environments do so at their own risk. The performance data contained herein was obtained in a controlled environment based on the use of specific data. Actual results that may be obtained in other operating environments may vary significantly. These values do not constitute a guarantee of performance.

References in this document to IBM and SAP products, programs, or services do not imply that IBM or SAP intend to make such products available in all countries in which each company operates. Neither IBM nor SAP warrants the others products. Each company's products are warranted in accordance with the agreements under which they are provided.

Version: 1.3  
June 24, 2005

Document Author:  
Sathees B Kodi/San Jose/IBM  
E-Mail: [satheesk@us.ibm.com](mailto:satheesk@us.ibm.com)  
Ph: 1-408-256-3065 (T/L 276-3065)



Document Owner:  
Amit Mathur/San Francisco/IBM  
E-Mail: [amitmat@us.ibm.com](mailto:amitmat@us.ibm.com)  
Ph: 1-408-256-9932 (T/L 276-9932)

## **Abstract**

The ability to quickly and easily clone SAP systems can be extremely valuable because of the many uses for a copy of the live production instance, including testing and problem analysis. Plain and simple, few things are better than testing on a copy of current data. Because a typical SAP R/3 environment often copies its production SAP database back to the test system as frequently as once a day, it is important to provide a quick clone of the production database with little or no impact to system performance.

IBM Consistency Group Technology can help deliver a “near-Instant” point-in-time copy of the production database using a globally consistent clone copy of the database. Once the copy is made, the other pre and post system cloning activities are performed through scripts. Users can employ this clone copy for quality assurance and testing of their system.

Using the advanced Copy Services functions of the IBM TotalStorage DS8000 storage server, users can create a clone copy while minizing impact on a live R/3 system. This “near-zero” downtime for the live R/3 system means that no transactions typically need to be cancelled during the copy procedure and that SAP users typically can avoid missing a beat while the cloning of the live database takes place.

## 1. Introduction

SAP System Cloning--also known as Homogeneous System Copy (HSC) creates a copy of an SAP R/3 system where the operating system and the database version are the same on the target system.

For HSC, the target SAP R/3 database server needs to have the same operating system (such as, AIX 5L) and the same database system (such as, Oracle 9i) as the source SAP R/3 system. The binaries and the contents of the database are copied from the source SAP R/3 system to the target SAP R/3 system through Copy Services FlashCopy® function with consistency group technology. Hence, the SAP and Oracle version/release of the source and target systems must remain the same. The advantage of having all binaries on storage disks is that there is never a need to install binaries on the cloned system again, which is a very cumbersome process.

IBM Consistency Group technology can help SAP customers create a clone of their production system with little or no impact on production servers. Earlier in 2002, a similar system cloning solution based on this concept was demonstrated using an Oracle8i database on the AIX 4.3.3 platform on the IBM TotalStorage® Enterprise Storage Server (ESS) model 800. A similar solution was also implemented on IBM ESS in March 2004. (Refer to the white paper entitled Consistency Technology for mySAP Business Suite – Creating Consistent Images of a Distributed System Landscape with IBM TotalStorage Enterprise Storage Server.) In the example used in this white paper a solution is implemented with a single DS8300 configuration using the DS8300 advanced functions – the local copy function FlashCopy with freeze option using consistency group technology. The core R/3 system was loaded using the SAP developed tool SSQJ to simulate online transactions.

The greatest potential benefit to the customer in the solution described herein is that the whole SAP System solution is automated through scripts. Customers can provide the input values in the main screen and can then make a clone copy in a few minutes while minimizing impact to the production system. The following SAP System Cloning information describes how users can implement the SAP R/3 System Cloning process on a DS8300 using a SAP 4.7/Oracle 9i/AIX 5L platform.

## 2. Customer Requirements

In an SAP R/3 environment, a system copy is performed using either SAP R/3 Export/Import tools or using database-specific tools. The SAP R/3 Export/Import procedure uses a standard SAP-supplied transaction to export the data from the source database to a flat file and then to import the data into the target database.

Note: This process is not recommended for large production SAP environments.

## 3. Introduction to the IBM TotalStorage DS8000 series

The newly released IBM Total Storage DS8000 series is designed to be a series of high performance, high-capacity disk storage systems for business critical enterprise storage workloads that is designed to support 24x7 operations. The DS8000 models use IBM POWER5<sup>®</sup> server technology that is integrated with IBM Virtualization Engine technology. DS8000 series model consists of one storage device and either one or two management consoles, two being the recommended configuration. The graphical user interface (GUI) or command-line interface (CLI) allows users to logically partition the storage, monitor I/O performance, and use the built-in Copy Services functions.

The DS8000 series is designed to provide high performance, connectivity and reliability, which allows the workload to be consolidated into a single storage subsystem.

The following list provides an overview of some of features that are associated with the DS8000 series that allow it to help address customer business requirements for performance and reliability.

### **POWER5 processor technology:**

The DS8000 features IBM's latest POWER5 technology.

### **Industry-standard fibre channel disk drives:**

The DS8000 series supports a selection of fibre channel disk drives, including 300 GB drives, allowing a DS8100 to scale up to 115.2 TB of capacity and a DS8300 to scale up to 192 TB of capacity.

### **Four port fibre channel/FICON adapters:**

New adapters are designed to not only enhance connectivity, but increase configuration flexibility because the individual ports can be configured to support fibre channel or FICON.

### **New processor memory offerings:**

The DS8100 offers up to 128 GB of processor memory and the DS8300 offers up to 256 GB of processor memory. In addition, the Non-Volatile Storage (NVS)

scales to the processor memory size selected, which can also help improve performance. Improved caching algorithms can also help enhance performance versus the ESS Model 800 through new technologies for managing cache space.

### **More host attachments than the IBM TotalStorage Enterprise Storage Server Model 800:**

The DS8100 offers up to 16 host adapters and the DS8300 offers up to 32 host adapters. This can be an intermix of ESCON and fibre channel/FICON adapters, further increasing your ability to share your disk storage.

### **New internal fabric:**

The DS8000 series features a new internal fabric which can help provide increased bandwidth and fault tolerant internal interconnection, which is also used in the IBM pSeries® Server. It is called RIO-2 (Remote I/O) and can operate at speeds up to 1 GHz and offers a 2 GB per second sustained bandwidth per link.

### **High availability:**

The DS8000 series is designed and implemented with component redundancy to help avoid many potential single points of failure.

### **Functional enhancements for flexibility and ease-of-use**

The DS8000 series offers functional enhancements and new capabilities that are designed to increase flexibility and usability.

### **Logical Unit Number (LUN) and volume management**

- Non-disruptive LUN and volume creation and deletion is now supported. When a LUN or volume is deleted, the capacity can be re-formatted and re-used.
- LUNs and volumes can be configured to span arrays. Therefore, the size of the volume/LUN is not constrained by the size of the array. LUNs up to 2 TB are supported. CKD volumes up to 65,520 cylinders are supported.

### **Addressing capabilities:**

More Logical Subsystems (LSS), logical devices, and logical paths can be defined versus the current DS8000.

- Up to 256 LSS
- Up to 65,280 logical devices
- Up to 130,560 FICON logical paths (512 logical paths per control unit image)
- Up to 8,000 procDS8000 logins (509 per SCSI-FCP port)

## 4. DS8000 Architecture

The DS8000 series architecture consists of two processor complexes as shown in Figure-1. Each processor complex has access to multiple host adapters to connect to channel, FICON and ESCON hosts. Each DS8000 series system can potentially have up to 32 host adapters. To access the disk subsystem, each complex uses several four port fibre-channel arbitrated loop (FC-AL) device adapters. A DS8000 series system can potentially have up to sixteen of these adapters arranged into eight pairs. Each adapter connects the complex to two separate switched fibre channel networks. Each switched network attaches disk enclosures that each contains up to 16 disks. Each enclosure contains two 20 port fibre channel switches. Of these 20 ports, 16 are used to attach to the 16 disks in the enclosure and the remaining four are used to either interconnect with other enclosures or to the device adapters. Each disk is attached to both switches. Whenever the device adapter connects to a disk, it uses a switched connection to transfer data. This means that all data travels via the shortest possible path.

The attached hosts interact with software which is running on the complexes to access data on logical volumes. Each complex will host at least one instance of this software (which is called a *server*), which runs in a logical partition (an LPAR). The servers manage all read and write requests to the logical volumes on the disk arrays. During write requests, the servers use fast-write where the data is written to volatile memory on one complex and persistent memory on the other complex. The server then reports the write as complete before it has been written to disk. This provides much faster write performance. Persistent memory is also called NVS or non-volatile storage.

When a host performs a read operation, the servers fetch the data from the disk arrays via the high performance switched disk architecture. The data is then cached in volatile memory in case it is required again. The servers attempt to anticipate future reads by an algorithm known as SARC (Sequential pre-fetching in Adaptive Replacement Cache). Data is held in cache as long as possible using this smart algorithm. If a cache hit occurs where requested data is already in cache, then the host does not have to wait for it to be fetched from the disks.

## SAP System Cloning Solution using the IBM TotalStorage DS8300

Both the device and host adapters operate on a high bandwidth fault-tolerant interconnect known as the RIO-G. The RIO-G design allows the sharing of host adapters between servers and supports exceptional performance and reliability.

The Figure -1 below shows the colors as indicators of how the DS8000 hardware is shared between the servers (the cross hatched color is green and the lighter color is yellow). On the left hand side, the green server is running on the left hand processor complex. The green server uses the N-way SMP of the complex to perform its operations. It records its write data and caches its read data in the volatile memory of the left hand complex. For fast write data it has a persistent memory area on the right hand processor complex. To access the disk arrays under its management (the disks also being pictured in green), it has its own device adapter (again in green). The yellow server on the right operates in an identical fashion. The host adapters (in dark red) are deliberately not colored green or yellow because they are shared between both servers. For complete details on DS8000 architecture please refer IBM Red Book "The IBM TotalStorage DS8000 Series: Concepts and Architecture" (SG24-6452-00).

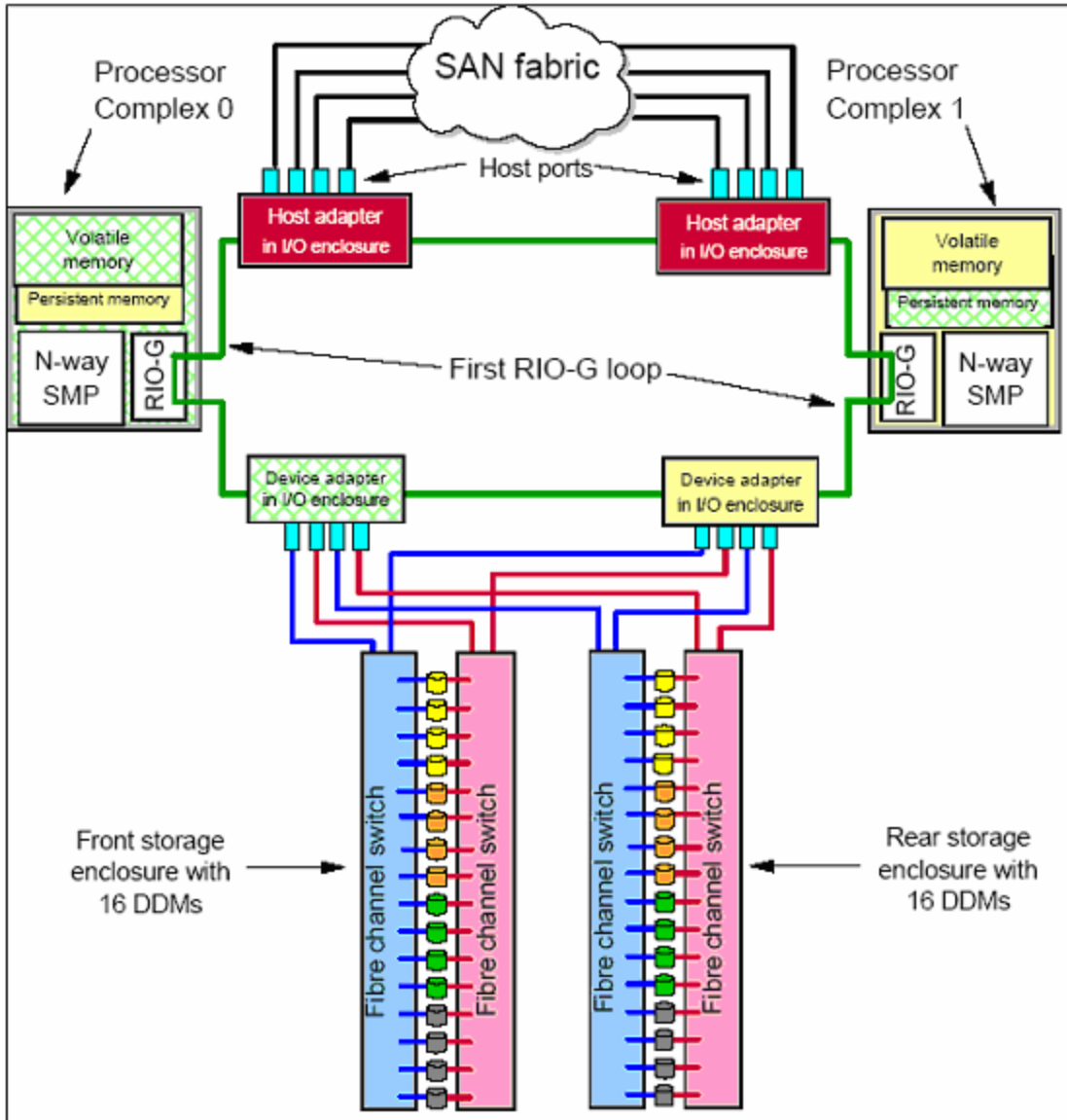

Figure-1

## 5. Advanced Copy Services:

Copy functions run on DS8000 series storage unit and support open systems and zSeries environments. These functions are supported also on the previous generation of storage systems called the IBM TotalStorage Enterprise Storage Server (ESS).

Many design characteristics of the DS8000 series and data copying and mirroring capabilities of advanced Copy Functions features contribute to the protection of your data. The licensed features included in Copy Functions are the following:

FlashCopy, which is a Point-in-Time Copy function

Remote Mirror and Copy functions, previously known as Peer-to-Peer Remote Copy or PPRC, which include:

- IBM TotalStorage Metro Mirror, previously known as Synchronous PPRC
- IBM TotalStorage Global Copy, previously known as PPRC Extended Distance
- IBM TotalStorage Global Mirror, previously known as Asynchronous PPRC
- z/OS Global Mirror, previously known as Extended Remote Copy (XRC)
- z/OS Metro/Global Mirror.

### Consistency Group Technology

IBM's Consistency Group Technology provides the consistency between any set of source and target volumes defined in a Consistency group for local copy within a storage system or remote mirror and copy between storage systems. The split mirror backup solution uses the consistency technology at FlashCopy level as well as at remote mirror and Copy level. With Copy Services, you can create *Consistency Groups* for FlashCopy and PPRC. Consistency Group is a function to keep *data consistency* in the backup copy. Data consistency means that the order of dependent writes is kept in the copy. For more details on Consistency Group refer the IBM red book "IBM TotalStorage Enterprise Storage Server Implementing ESS Copy Services in Open Environments."

### Consistency Group FlashCopy

If a consistent point-in-time copy across many logical volumes is required, and the user does not wish to quiesce host I/O or database operations, then the user may use Consistency Group FlashCopy to create a consistent copy across multiple logical volumes in multiple storage units.

In order to create this consistent copy, the user would issue a set of Establish FlashCopy commands with a *freeze* option, which will hold off host I/O to the source volumes. In other words, Consistency Group FlashCopy provides the capability to temporarily queue (at the host I/O level, not the application level) subsequent write operations to the source volumes that are part of the Consistency Group. During the temporary queuing, Establish FlashCopy is completed. The temporary queuing continues until this condition is reset by the

“unfreezeflash” command or the time-out value expires (the default is two minutes).

## 6. Installation Preparations and Lab Setup

The name of the production host (AIX LPAR) is “spyder”. The clone host name is “crossfire”. The two hosts are connected to the both DS8300 boxes as shown in Figure 2. These two hosts are connected to the DS8300 storage server through SAN switch using fibre channel cables. The DS8300 server name is “OSLSQ04”.

The OS software that is used in this solution is AIX 5L (5.2.0.0) and application software used is SAP 4.7 with Oracle 9i. The tool that is used to create the load simulation on the SAP system is the SAP-designed SSQJ 9. SSQJ is a generic test measurement tool that was developed with ABAP/4 and function modules in core R/3.

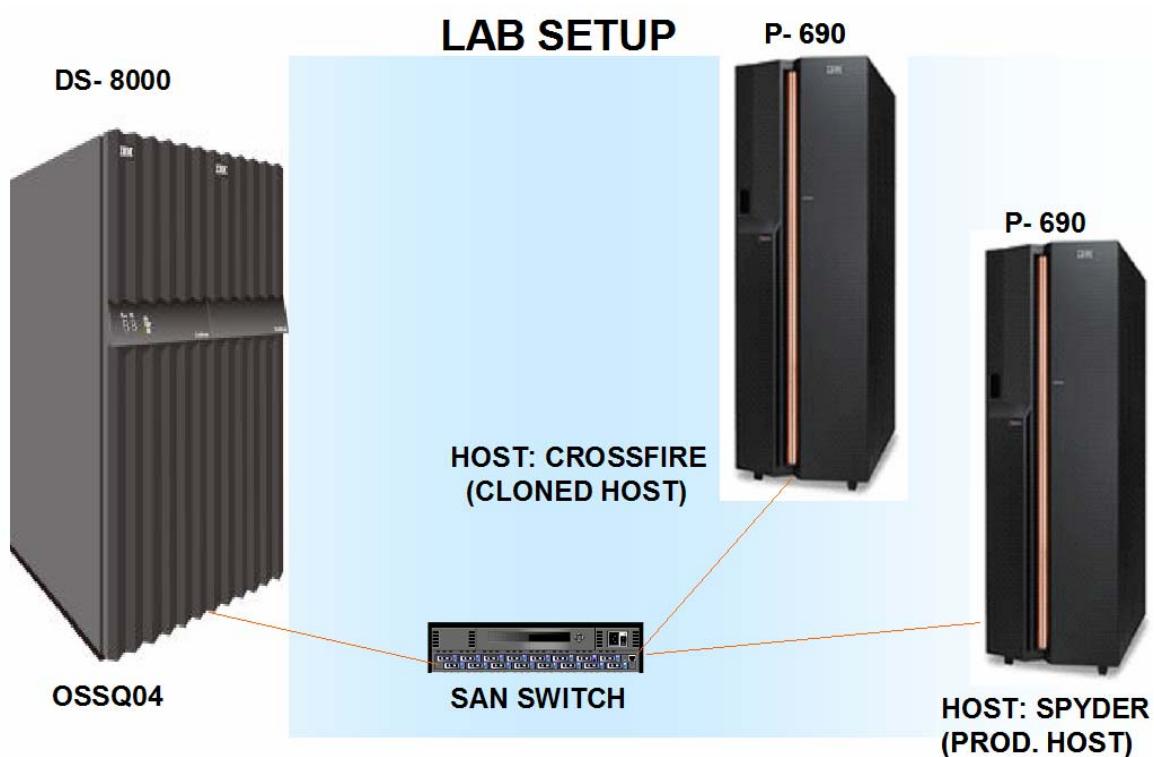

Figure 2

## 7. SAP/Oracle Database Layout

The SAP and Oracle File systems that are used in this system cloning solution are depicted in the following table. The LUN sizes used are 1 GB, 2 GB, 5 GB, 10 GB, 20 GB, 40 GB and 60 GB. The LUNs on DS8300 can be created across the ranks from a single extent pool, which provides more flexibility and performance benefits to the customers. It is better if the file system /oracle/S01/oraarch exists on a separate disk (LUN) in order to re-sync the archive log files in the hot backup process, but the Oracle hot / Online backup is not required if storage centric consistency groups and the freeze option are available. The disk group S01sap07vg (File system /oracle/S01/sapdata5) is created to store SSQJ tablespaces.

Disk Group	File System Name	Function	LUN's	Size
<b>S01sap00vg</b>	/usr/sap/S01	work & global directory	2500-2502	5 GB
	/sapmnt/S01	SAP executables		2 GB
	/usr/sap/trans	Transport Directory		10 GB
<b>S01sap01vg</b>	/oracle/S01/origlogA	Online redo log files set I	2503-2508	512 MB
	/oracle/S01/mirrlogB	Online redo log files set II		512 MB
	/oracle/S01/mirrlogA	Mirror of origlogA files		512 MB
	/oracle/S01/origlogB	Mirror of origlogB files		512 MB
	/oracle/S01/sapreorg	Temporary data staging		2 GB
<b>S01sap02vg</b>	/oracle	Oracle base directory	2508-250D	256 MB
	/oracle/client	Oracle Client		512 MB
	/oracle/S01	Oracle Instance specific directory		3 GB
	/oracle/S01/920_64	Oracle Executables		4 GB
	/oracle/stage/920_64	Oracle Staging Area		2.5 GB
<b>S01sap03vg</b>	/oracle/S01/sapdata1	SAP R/3 data files	250E, 2510	30 GB
<b>S01sap04vg</b>	/oracle/S01/sapdata2	SAP R/3 data files	250F, 2511	30 GB
<b>S01sap05vg</b>	/oracle/S01/sapdata3	SAP R/3 data files	2512-2517	60 GB
<b>S01sap06vg</b>	/oracle/S01/sapdata4	SAP R/3 data files	251C,251D, 2518, 2519	80 GB
<b>S01sap07vg</b>	/oracle/S01/sapdata5	SAP R/3 data files	251E-2520	80 GB
<b>S01sap08vg</b>	/oracle/S01/oraarch	Archive log files	2521	40 GB

Figure 3

## 8. Homogeneous System Copy Process

Figure 4 shows a typical SAP system cloning process within the same DS8300 storage server. The letters “DB<sub>A</sub>” represents the production volumes and the letters “DB<sub>B</sub>” represents the FlashCopy target volumes on the primary DS8300. In this solution, FlashCopy consistency groups with the freeze option is used to make global consistent copy.

For more details on consistency group technology, please refer to the white paper “Consistency Technology for mySAP Business Suite – Creating Consistent Images of a Distributed System Landscape With the IBM TotalStorage Enterprise Storage Server (ESS)”.

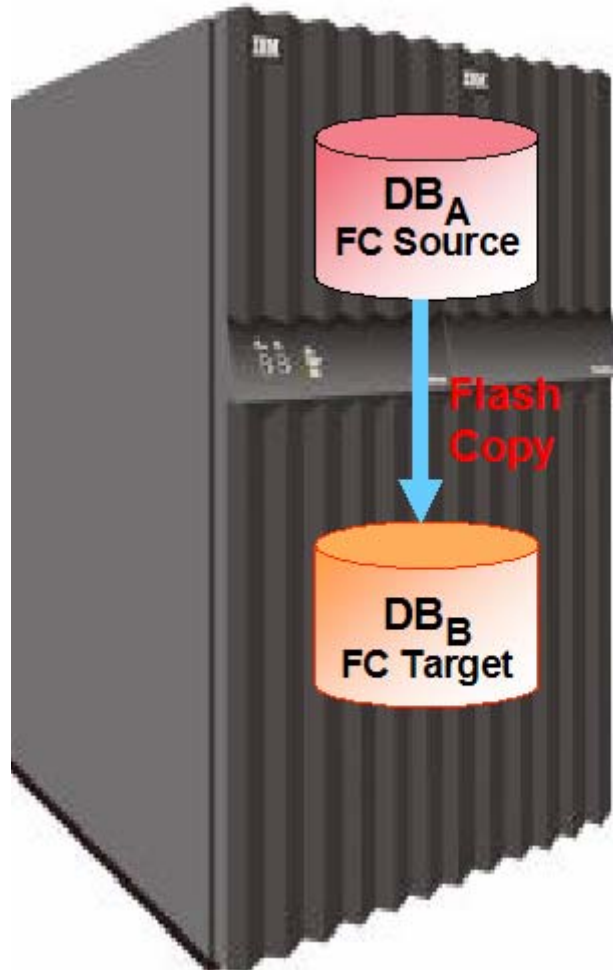
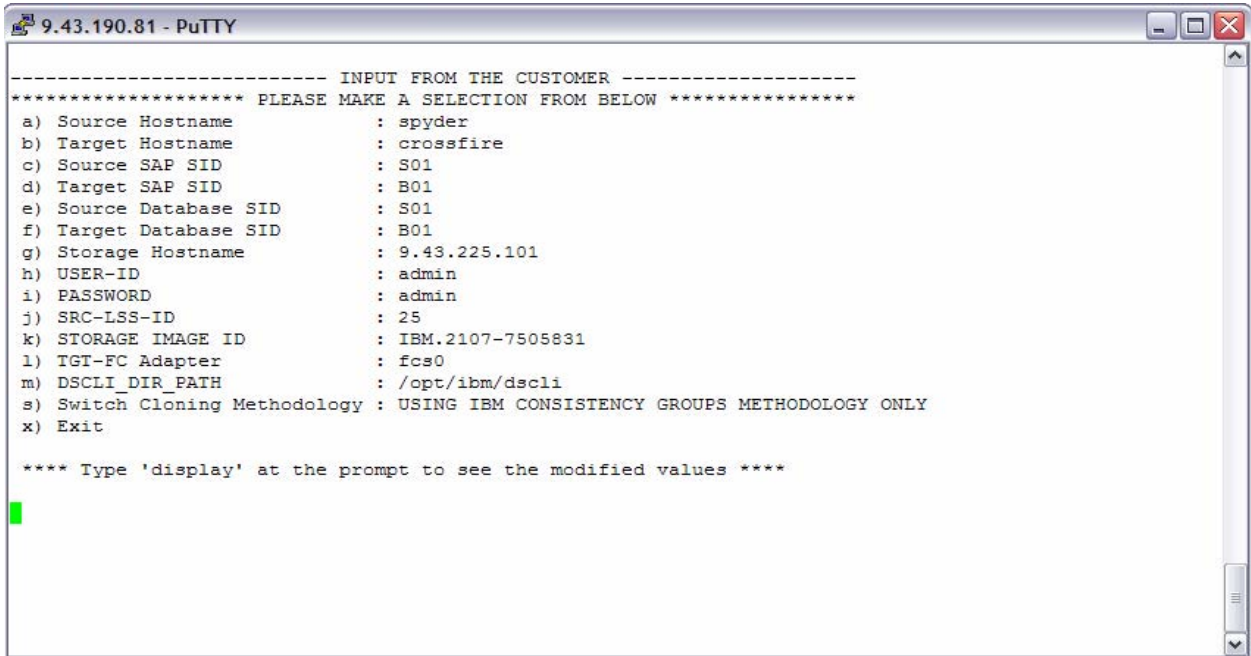

Figure 4

Figure 5 shows the main screen menu where the user can check or input the values and then edit them per the requirement.



```
9.43.190.81 - PuTTY
----- INPUT FROM THE CUSTOMER -----
***** PLEASE MAKE A SELECTION FROM BELOW *****
a) Source Hostname      : spyder
b) Target Hostname     : crossfire
c) Source SAP SID      : S01
d) Target SAP SID      : B01
e) Source Database SID : S01
f) Target Database SID : B01
g) Storage Hostname    : 9.43.225.101
h) USER-ID            : admin
i) PASSWORD            : admin
j) SRC-LSS-ID          : 25
k) STORAGE IMAGE ID    : IBM.2107-7505831
l) TGT-FC Adapter      : fcs0
m) DSCLI_DIR_PATH     : /opt/ibm/dscli
s) Switch Cloning Methodology : USING IBM CONSISTENCY GROUPS METHODOLOGY ONLY
x) Exit

**** Type 'display' at the prompt to see the modified values ****
```

Figure 5

### **System Cloning Process Scenario**

The initial state of the production system is the normal READ/WRITE operation. The SAP system copy starts with freezing the I/O to all production volumes using consistency group technology and the FlashCopy feature. Once the FlashCopy logical copy is completed, the I/O to the production volumes is resumed so that the production can continue without any problems. The following HSC scenario has been tested in the lab.

The copy made using the FlashCopy consistency groups freeze option is recovered at the target (cloned) host by performing a crash recovery operation. Although further log roll forwarding is not possible, it is a time saving and quick way of making a clone of the production database. The copy made using the Oracle Hot/Online Backup methodology with the FlashCopy function takes a little more time compared to the freeze option methodology. Hence in the shell scripts menu, there is an option for the users to turn on the Oracle online backup process. Although the System Cloning method does not require the Oracle Hot Backup methodology, the storage Copy Services feature plays a large role in creating the global consistent image.

The SAP System Cloning steps are listed below.

### General Process

1. If SAP, is running on the target system, shutdown SAP.
2. If Oracle is running on the target system, then shutdown the Oracle database and the listener.
3. Make sure that no SAP and Oracle processes are running on target host.
4. Unmount the SAP and Oracle file systems.
5. Vary-off and export the volume groups.
6. Switch redo log file force fully. [optional ]
7. Keep all tablespaces in Begin Backup Mode. [optional ]
8. Suspend the Oracle Database. [optional ]
9. Withdraw the FlashCopy relationship between the source and target volumes.
10. Perform the FlashCopy function on all SAP volumes using Consistency Group technology (using the -freeze record and persist options).
11. Resume I/O on source volumes (unfreeze).
12. Resume the Oracle Database. [ optional ]
13. Keep all tablespaces in End Backup Mode. [optional ]
14. Backup the Control file. [ optional ]
15. Switch the Log file to obtain the latest transaction changes from the source system. [ optional]
16. Resynch the existing archive volumes (ARCHIVE VOLUMES ONLY). [optional – oracle online backup methodology]  
[Step 7, 8, 12, 13, 14, 15 and 16 are not needed if storage centric freeze with consistency group technology is used.](#)
17. Import SAP and Oracle volume groups on the target host.
18. Mount SAP and Oracle file systems using the same SRC\_SID name on the target host.
19. If the required users and groups do not exist on the target host, then create them.
20. Change ownership of SRC SID files
21. Edit HOSTNAME in listener.ora and tnsnames.ora files.
22. Start Oracle by performing a crash recovery function.
23. Remove the old trace files and Control file trace.
24. Take the Control file backup to trace in order to edit the sid name at the database level.
25. Shutdown the database.
26. Copy the control trace file to the home directory of ora<TGT\_SID> user and change the ownership.
27. Edit the control file in the following places:
  - Change the Database name to the Target Database name.the
  - Remove first few lines from the Controlfile, that is, delete all the lines until the end of the statement that starts with "Create".
  - Change the line  
"CREATE CONTROLFILE REUSE DATABASE <SRC\_SID> NORESETLOGS ARCHIVELOG"  
to  
"CREATE CONTROLFILE SET DATABASE <TGT\_SID> RESETLOGS ARCHIVELOG"
  - Remove the last lines in the file pertaining to recovery, archiving and altering the database. Save the file as "controlfile.sql".
28. Unmount the SAP and Oracle file systems

29. Replace SRC\_SID with TGT\_SID in **/etc/filesystems** file
30. Mount SAP and Oracle filesystems with TGT\_SID.
31. Make all necessary changes to the DB environment, SAP environment profile files for users ora<TGT\_SID> & <TGT\_SID>adm respectively and rename files to reflect the target environment.
32. Make all necessary changes to **tnsnames.ora**, **listener.ora** and initialization files (**init<SRC\_SID>.ora**, **init<SRC\_SID>.dba** & **init<SRC\_SID>.sap**) to reflect the target environment.
33. Change all occurrences of SRC\_SID to TGT\_SID in **/etc/services** file on TARGET HOST.
34. Create the Oracle link libraries.
35. Delete the old control files.
36. Start the database with <TGT\_SID> and listener.
37. Create a new \$OPS<TGT\_SID>ADM user using the CHDBPASS utility.
38. Create the SAP links.
39. Make all necessary changes to the SAP profiles to reflect the target environment.
40. Perform postsystem cloning activities such as deleting spool lists.
41. Start SAP with TGT\_SID.
42. Apply the SAP license manually.

### **System Cloning Process Overview:**

There have been specific steps that are unique to the new SAP version 4.7. In prior releases, the database schema name was SAPR3. As of release 4.7, the schema is defined during the installation. With that in mind, one can plan the installations with specific schema names. If the schema names are different between systems, UNIX environmental variables must be modified after a database copy from one system to another.

The Clone process is divided into five phases:

1. Preparatory phase
2. FlashCopy phase
3. Restore phase
4. Clone phase
5. Post copy phase

This SAP System Cloning white paper describes each of these steps in detail, using actual scripts and syntax to show how each phase is processed. To facilitate the discussion, the following table shows the naming conventions used throughout this paper.

<b>Naming Convention</b>	<b>Description</b>
SRC_SID	Source database system identifier
TGT_SID	Target database system identifier
SRC_HOST	Source database hostname
TGT_HOST	Target database hostname

Additionally, the example in this white paper makes the following assumptions:

1. The SAP system B01 is installed and operational on TGT\_HOST.
2. The SAP system S01 is installed and operational on SRC\_HOST.

### I. Prepare Phase (Target System)

1. If SAP is running on the target system, shutdown SAP:  
su -<tgt\_sid>adm -c 'stopsap all DVEBMGS00'  
su -<tgt\_sid>adm -c 'cleanipc 00 remove'  
su -<tgt\_sid>adm -c 'saposcol -k'
2. If Oracle is running on the target system, then shutdown the Oracle database and listener:  
sql> shutdown immediate
3. Unmount the SAP and Oracle file systems.
4. Vary-off the volume groups.
5. Export the volume groups.

### II. Flash Copy Phase

6. Switch log file force fully. [optional – oracle online backup methodology]  
sql> alter system switch logfile;
7. Keep all tablespaces in Begin Backup Mode. [optional – Oracle online backup methodology]  
sql> alter tablespace <tablespacename> begin backup;
8. Suspend the Oracle Database. [optional – Oracle online backup methodology]  
sql> alter system suspend;
9. Withdraw the FlashCopy relationships between source and target volumes:  
dscli> rmflash -dev <storage image id> src\_luns:tgt\_luns
10. Run FlashCopy function on all SAP volumes using Consistency Group technology (using the -freeze record and persist options):  
dscli> mkflash -dev <storage image id> -freeze -record -persist  
src\_luns:tgt\_luns
11. Resume I/O on source volumes (unfreeze):  
dscli> unfreezeflash -dev <storage image id> src\_lss\_id

12. Resume the Oracle Database. [ optional – oracle online backup methodology ]  
sql> alter system resume;
13. Keep all tablespaces in End Backup Mode. [optional – Oracle online backup methodology]  
sql> alter tablespace <tablespacename> end backup;
14. Backup Control File. [ optional – Oracle online backup methodology ]  
sql> alter database backup controlfile to '\${backup\_dir}/cntrl .dbf. \${current-time}'
15. Switch the Log file to obtain the latest transaction changes from the source System. [ optional – oracle online backup methodology ]  
sql> alter system archive log current;
16. Resynch the existing archive volumes (archive volumes only). [optional – oracle online backup methodology]  
dscli> resyncflash –dev <storage image id> -freeze –record –persist  
src\_luns:tgt\_luns

Step 7, 8, 12, 13, 14, 15 and 16 are not needed if you use storage centric consistency group technology.

### III. Restore Phase (Target System)

17. Import the SAP and Oracle volume groups on the target host.
18. Mount the SAP and Oracle file systems using the same src\_sid name on target host.
19. Create the following users and groups on the target host:  
Groups : dba, sapsys  
Users : ora<src\_sid>, ora<tgt\_sid>, <src\_sid>adm and <tgt\_sid>adm.
20. Change the ownership of the src\_sid files:  
chown –R ora<src\_sid>:dba /oracle  
chown –R ora<src\_sid>:dba /oracle/ src\_sid
21. Edit the host name in the listener.ora and tnsnames.ora files:  
cp listener.ora listener.ora.old  
sed –e 's/ src\_host/tgt\_host/g' < listener.ora.old > listener.ora  
cp tnsnames.ora tnsnames.ora.old  
sed –e 's/ src\_host/tgt\_host/g' < tnsnames.ora.old > tnsnames.ora

22. Start Oracle by performing the crash recovery function:

```
sql> set autorecovery on;  
sql> startup;
```

**Note:** Crash recovery is required if IBM consistency groups technology is used. Point in time recovery is required if both IBM consistency groups technology and oracle online backup methodology are used.

23. Remove the old trace files and Control file trace:

```
rm /oracle/ src_sid /saptrace/*.trc
```

24. Take the Control file backup to trace in order to edit the sid name at the database level:

```
sql> alter database backup controlfile to trace;
```

25. Shutdown the database:

```
sql> shutdown immediate;
```

26. Copy the control trace file to the home directory of ora<tgt\_sid> user and change the ownership:

```
cp /oracle/ src_sid /saptrace/*.trc /home/ ora<tgt_sid>
```

27. Edit the control file in the following places:

- Change the database name to the target database name
- Remove the first few lines from the Control file, that is, delete all the lines until the end of the statement that starts with “Create”.
- Change the line

```
“CREATE CONTROLFILE REUSE DATABASE <SRC_SID> NORESETLOGS  
ARCHIVELOG”
```

to

```
“CREATE CONTROLFILE SET DATABASE <TGT_SID> RESETLOGS  
ARCHIVELOG”
```

- Remove the last lines in the file that pertain to recovery, archiving and altering the database. Save the file as “controlfile.sql”.

28. Unmount the SAP and Oracle file systems.

29. Replace src\_sid with tgt\_sid in the /etc/filesystems file:

```
cp etc/filesystems etc/filesystems.old  
sed -e 's/src_sid/tgt_sid/g' < etc/filesystems.old > etc/filesystems
```

30. Mount the SAP and Oracle file systems with tgt\_sid.

#### IV. Clone Phase (Target System)

31. Change all occurrences of src\_sid to tgt\_sid, src\_host to tgt\_host in the database environment, SAP environment profile files for users ora<tgt\_sid> and <tgt\_sid>adm respectively, and rename files to reflect the target host.

**Note:** Make sure that dbs\_ora\_schema is set to SAP< src\_sid> in environment profile files for users ora<tgt\_sid> and <tgt\_sid>adm

32. Edit database sid, hostname in tnsnames.ora, listener.ora and initialization files (init<src\_sid>.ora, init<src\_sid>.dba & init<src\_sid>.sap) and rename the initialization files to reflect tgt\_sid (init<tgt\_sid>.ora, init<tgt\_sid>.dba and init<tgt\_sid>.sap)

33. Change all occurrences of src\_sid to tgt\_sid in the /etc/services file on the target host.

34. Create the Oracle link libraries:

```
su - ora<tgt_sid> -c '${tgt_oracle_home}/rdbms/lib make -f ins_rdbms.mk ioracle llibobk=-lobk'
```

35. Delete the old control files:

```
rm /oracle/ tgt_sid /sapdata1/cntrl.dbf
rm /oracle/ tgt_sid /saparch/cntrl.dbf
rm /oracle/ tgt_sid /origlogA/cntrl.dbf
```

36. Start the database with <tgt\_sid>:

```
sql> @controlfile.sql
sql> alter database open resetlogs;
```

37. Start listener:

```
su - ora<tgt_sid> -c 'lsnrctl start'
```

38. Create a new \$OPS<TGT\_SID>ADM user using the chdbpass utility.

### V. Post-copy Phase (Target System)

39. Create SAP links

```
In -s /sapmnt/src_sid/exe /sapmnt/tgt_sid/exe
```

40. Change all occurrences of src\_sid and src\_host in SAP profile files default.pfl, instance profile (<src\_sid>\_dvebmgs00\_<src\_host>) and startup profile (start\_dvebmgs00\_<src\_host>), and rename the profile files to reflect changes in tgt\_sid and tgt\_host.

\*\*\* set rdisp/wp\_no\_btc=0, so that no background jobs kick-off when cloned system is started

### 41. Post System Cloning Activities

- Disable RFC Connections (table: RFCDES)
- Delete all print jobs and their lists (tables: TSP01, TSP02, TSP02F, TSP02L, TSP0E, TSPEVJOB, TST01 and TST03).
- Clean the information for application-buffer synchronization (table: DDLOG)
- Set a system message that the clone is a copy of the production system

### 42. Start SAP with tgt\_sid:

```
su -<src_sid>adm -c 'startsap all DVEBMGS00'
```

### 43. Apply the SAP license manually:

```
su -<src_sid>adm -c 'saplicense -install'
```

## Appendix

### 9. Sample Cloning Scripts

#### *Main Script*

```
#!/usr/bin/ksh
##### Script to clone a SAP Instance with
Oracle 9i on an AIX based
# system using IBM TotalStorage Copy Services
#####
FCS_DIR=`pwd`
LIB_DIR=${FCS_DIR}/lib
THISHOST=`uname -n`
DATE=`date | cut -d" " -f5`

#----- Check Environment Variables for Shell -----
${LIB_DIR}/checkenv.sh
echo " **** Do you want to continue with the Cloning Activities **** "
echo " **** Please enter 'Y' for to continue "
read INPUT

#----- SOURCE Environment Variables for Shell -----
. ${LIB_DIR}/env_source.sh
check 01 /* function to check the return code status */

if [ "$INPUT" = "Y" ] && [ "${THISHOST}" != "${TGT_HOST}" ]; then

#----- PREPARE PHASE -----
time ${SCRIPT_DIR}/prepare.sh 2>&1 | tee ${LOG_DIR}/prepare.log
check 02

#----- Flash-Copy Phase -----
time ${SCRIPT_DIR}/flashcopy.sh 2>&1 | tee ${LOG_DIR}/flashcopy.log
echo $?
check 03

#----- RESTORE PHASE -----
time ${SCRIPT_DIR}/restore.sh 2>&1 | tee ${LOG_DIR}/restore.log
check 04

#----- CLONE PHASE -----
time ${SCRIPT_DIR}/clone.sh 2>&1 | tee ${LOG_DIR}/clone.log
check 05

#----- POST-COPY PHASE -----
time ${SCRIPT_DIR}/postcopy.sh 2>&1 | tee ${LOG_DIR}/postcopy.log
check 06

else
echo "\n **** Re-run the script to modify SOURCE Environment Variables for Shell \
& then proceed with Cloning Activities ****\n"
exit 0
fi
#----- Finish -----
```

## Prepare Script on Target host

```
#!/bin/ksh
#####
#Prepare phase execution script
#####
if [[ -z ${SCRIPT_DIR} ]]
then
    ./scripts/fcs/lib/env_source.sh
fi
echo "\n `date | tr -s ' ' | cut -f4 -d ' ' ` ---- STEP 1 : STARTING PREPARE PHASE ----\n"
echo "`date | tr -s ' ' | cut -f4 -d ' ' -- STOP SAP --> CLEAN SHARED MEMORY --> STOP OS COLLECTOR --> LISTENER\n"
count=`ssh ${TGT_HOST} "ps -ef | grep sap | wc -l"`
if [ "$count" -ne 1 ]; then
ssh ${TGT_HOST} "su - ${TGT_SAP_OWNER_ID} -c stopsap all DVEBMGS00"
ssh ${TGT_HOST} "su - ${TGT_SAP_OWNER_ID} -c cleanipc 00 remove"
ssh ${TGT_HOST} "su - ${TGT_SAP_OWNER_ID} -c saposcol -k"
    if [ $? -ne 0 ]; then
        echo "Warning: make sure no SAP processes are running ${TGT_HOST}"
    fi
fi
count=`ssh ${TGT_HOST} "ps -ef | grep ora | wc -l"`
if [ "$count" -ne 1 ]; then
ssh ${TGT_HOST} "su - ${TGT_DB_OWNER_ID} -c lsnrctl stop"
ssh ${TGT_HOST} "su - ${TGT_DB_OWNER_ID} -c 'sqlplus \"/as sysdba\'' <<EOF
SHUTDOWN IMMEDIATE
EOF
fi
    if [ $? -ne 0 ]; then
        echo "Warning: make sure no Oracle processes are running ${TGT_HOST}"
    fi
fi
echo "`date | tr -s ' ' | cut -f4 -d ' ' -- SAP and Oracle are stopped on ${TGT_HOST} \n"
echo "`date | tr -s ' ' | cut -f4 -d ' ' -- Un-Mounting File Systems on ${TGT_HOST} \n"
ssh ${TGT_HOST} "lsfs | egrep 'lv' | egrep 'oracle|sap|${SRC_DB_SID}|${TGT_DB_SID}' | \
| tr -s ' ' | cut -d ' ' -f3 | sort -r" > ${TEMP_DIR}/fs.list
if [ -s ${TEMP_DIR}/fs.list ]; then
for fs in `cat ${TEMP_DIR}/fs.list`
do
ssh ${TGT_HOST} "fuser -k $fs" > /dev/null 2>&1
ssh ${TGT_HOST} "umount $fs" > /dev/null 2>&1
done
fi
check 07
echo "`date | tr -s ' ' | cut -f4 -d ' ' -- Un-Mounting File Systems on ${TGT_HOST} Successful \n"
echo "`date | tr -s ' ' | cut -f4 -d ' ' -- Varyoffvg and exportvg on ${TGT_HOST} \n"
for fvg in `ssh ${TGT_HOST} "lsvg | grep ${TGT_DB_SID}"`
do
count=`ssh ${TGT_HOST} "lsvg -l $fvg | grep paging | wc -l`
if [[ $count -eq 0 ]]; then
ssh ${TGT_HOST} "/usr/sbin/varyoffvg $fvg"
else
for pg in `ssh ${TGT_HOST} "lsvg -l $fvg" | grep paging | cut -d " " -f1`
do
ssh ${TGT_HOST} "swapoff /dev/$pg" > /dev/null 2>&1
done
ssh ${TGT_HOST} "/usr/sbin/varyoffvg $fvg"
fi
check 08
echo "`date | tr -s ' ' | cut -f4 -d ' ' -- ${fvg} on ${TGT_HOST} - varyoffvg - successful"
ssh ${TGT_HOST} "/usr/sbin/exportvg $fvg"
check 09
echo "`date | tr -s ' ' | cut -f4 -d ' ' -- ${fvg} on ${TGT_HOST} - exportvg - successful"
done
echo "`date | tr -s ' ' | cut -f4 -d ' ' -- Varyoffvg and exportvg on ${TGT_HOST} Successful \n"
```

## SAP System Cloning Solution using the IBM TotalStorage DS8300

```
echo "`date | tr -s ' ' | cut -f4 -d ' '`" -- Removing VPATH's on ${TGT_HOST} \n"
count=`ssh ${TGT_HOST} "lspv | grep vpath | wc -l"`
if [ "$count" -ne 0 ]; then
ssh ${TGT_HOST} "rmdev -dl dpo -R" >> ${LOG_DIR}/prepare.log 2>&1
check 10
fi
echo "`date | tr -s ' ' | cut -f4 -d ' '`" -- Remove VPATH's on ${TGT_HOST} Successful \n"
echo "`date | tr -s ' ' | cut -f4 -d ' '`" -- Removing physical disks on ${TGT_HOST} \n"
count=`ssh ${TGT_HOST} "lspv | grep hdisk | tr -s ' ' | cut -d ' ' -f2 | grep -i None | wc -l"`
if [ "$count" -ne 0 ]; then
ssh ${TGT_HOST} "rmdev -dl ${TGT_FC_ADAPTER_FSCSI} -R" >> ${LOG_DIR}/prepare.log 2>&1
check 11
fi
echo "`date | tr -s ' ' | cut -f4 -d ' '`" -- Remove Physical disks for ${TGT_FC_ADAPTER_FSCSI} on ${TGT_HOST}
Successful \n"
echo "\n `date | tr -s ' ' | cut -f4 -d ' '`" ----- STEP 1 : PREPARE PHASE COMPLETED SUCCESSFULLY ----- \n"
```

User has to provide the disk (LUN) information in the input Config file as shown below in blue color.

### ***Input Config File***

---

**/lib/fcs\_vols.dat**

---

```
## Example of 1 to 1 luns:
##### lunA:lunB
## Example of grouped luns
##### lunA1-lunA4:lunB1-lunB4
## Example of grouped ARCHIVE luns
##### lunA6-lunA7:lunB6-lunB7:IARCH
2500-2521:2700-2721
2521:2721:ARCH
```

### **Hardware used for the system cloning solution**

The following hardware is used for the system cloning solution in the lab.

<b>Server System</b>	<b>IBM pSeries 690 24 CPUs, 32 GB Memory dividable into 32 partitions (nodes)</b>		
<b>Host</b>	<b>Used as</b>	<b>CPUs</b>	<b>Memory</b>
spyder	Production System	6	6 GB
crossfire	Backup System	4	6 GB
<b>Storage System</b>	<b>IBM DS8000 1 (7505831) :</b>		
<b>Disk</b>	<b>Characteristics</b>	<b>Size</b>	<b>Number</b>
<b>Physical Drive</b>	RAID 5	2 GB	2 x 8
<b>Physical Drive</b>	RAID 5	5 GB	2 x 8
<b>Physical Drive</b>	RAID 5	10 GB	2 x 12
<b>Physical Drive</b>	RAID 5	20 GB	2 x 4
<b>Physical Drive</b>	RAID 5	40 GB	2 x 4
<b>Connection</b>	<b>Switched Fibre Fabric (1 Brocade 16 Port Switch)</b>		
<b>Switch to</b>	<b>Characteristics</b>	<b>Number</b>	
<b>Server-Node</b>	LP9802	1	

### **Software used for the system cloning solution**

The following software is used for the system cloning solution in the lab.

<b>Type</b>	<b>Software</b>	<b>Version</b>
<b>Storage</b>	IBM DS8300 Microcode Level	6.0.0.319
	IBM DSCLI	5.0.3.61
<b>Operating System</b>	AIX 5L	5.2.0.0-02
<b>Database System</b>	Oracle 9i	9.2.0.6
<b>SAP</b>	S01 – Production Central and DB Instance	4.7
	B01 – Backup Central and DB Instance	4.7
<b>Miscellaneous</b>	OpenSSH	3.8.1p1
	OpenSSL	0.9.7d

### Logs

The output is directed to various log files in order to identify the errors easily.

### Prepare phase log

12:02:40 ----- STEP 1 : STARTING PREPARE PHASE -----

12:02:40-- STOP SAP --> CLEAN SHARED MEMORY --> STOP OS COLLECTOR --> LISTENER

Stopping the SAP instance DVEBMGS00

-----  
Shutdown-Log is written to /home/b01adm/stopsap\_DVEBMGS00.log  
Instance on host crossfire stopped  
Waiting for cleanup of resources.....  
Running /usr/sap/B01/SYS/exe/run/stopdb  
Trying to stop B01 database ...  
Log file: /home/b01adm/stopdb.log  
B01 database stopped  
/usr/sap/B01/SYS/exe/run/stopdb completed successfully

Show/Cleanup SAP-IPC-Objects V2.3, 94/01/20

=====

Running SAP-Systems (Nr)....

-----  
---- Clear IPC-Objects of Sap-System 0 -----  
-----  
OsKey: 10016 0x00002720 Shared Memory Key: 16 removed  
OsKey: 3000283 0x002dc7db Event Flag Key: 283 removed  
OsKey: 58900100 0x0382be84 SCSA Shared Memory removed

Number of IPC-Objects.....: 3  
Number of removed IPC-Objects...: 3  
Summary of all Shared Memory....: 131.5 MB (may be incomplete when not in superuser mode)  
12:03:09 28.04.2005 LOG: ==== Stop Flag was set by saposcol (kill\_collector()).

12:03:09 28.04.2005 LOG: ==== The collection process will stop as soon as possible

Setting Stop Flag :  
Collecting process has stopped.

LSNRCTL for IBM/AIX RISC System/6000: Version 9.2.0.6.0 - Production on 28-APR-2005 12:03:11

Copyright (c) 1991, 2002, Oracle Corporation. All rights reserved.

Connecting to (ADDRESS=(PROTOCOL=IPC)(KEY=B01.WORLD))  
The command completed successfully

SQL\*Plus: Release 9.2.0.6.0 - Production on Thu Apr 28 12:03:12 2005

Copyright (c) 1982, 2002, Oracle Corporation. All rights reserved.

Connected to an idle instance.

SQL> ORA-01034: ORACLE not available  
ORA-27101: shared memory realm does not exist  
IBM AIX RISC System/6000 Error: 2: No such file or directory  
SQL> Disconnected  
12:03:11-- SAP and Oracle are stopped on crossfire

12:03:11-- Un-Mounting File Systems on crossfire

12:03:32-- Un-Mounting File Systems on crossfire Successful

12:03:32-- Varyoffvg and exportvg on crossfire

## SAP System Cloning Solution using the IBM TotalStorage DS8300

12:03:33-- B01sap00vg on crossfire - varyoffvg - successful  
12:03:34-- B01sap00vg on crossfire - exportvg - successful  
12:03:36-- B01sap01vg on crossfire - varyoffvg - successful  
12:03:37-- B01sap01vg on crossfire - exportvg - successful  
12:03:38-- B01sap02vg on crossfire - varyoffvg - successful  
12:03:39-- B01sap02vg on crossfire - exportvg - successful  
12:03:40-- B01sap03vg on crossfire - varyoffvg - successful  
12:03:41-- B01sap03vg on crossfire - exportvg - successful  
12:03:42-- B01sap04vg on crossfire - varyoffvg - successful  
12:03:43-- B01sap04vg on crossfire - exportvg - successful  
12:03:44-- B01sap05vg on crossfire - varyoffvg - successful  
12:03:45-- B01sap05vg on crossfire - exportvg - successful  
12:03:47-- B01sap06vg on crossfire - varyoffvg - successful  
12:03:47-- B01sap06vg on crossfire - exportvg - successful  
12:03:50-- B01sap07vg on crossfire - varyoffvg - successful  
12:03:51-- B01sap07vg on crossfire - exportvg - successful  
12:03:52-- B01sap08vg on crossfire - varyoffvg - successful  
12:03:53-- B01sap08vg on crossfire - exportvg - successful  
12:03:54-- B01sap09vg on crossfire - varyoffvg - successful  
12:03:55-- B01sap09vg on crossfire - exportvg - successful  
12:03:55-- Varyoffvg and exportvg on crossfire Successful

12:03:55-- Removing VPATH's on crossfire  
12:03:56-- Removing physical disks on crossfire  
12:04:03-- Remove Physical disks for fscsi0 on crossfire Successful

12:04:03 ----- STEP 1 : PREPARE PHASE COMPLETED SUCCESSFULLY -----

### FlashCopy phase log

12:04:04----- STEP 2: STARTING FLASH-COPY PHASE -----

12:04:04-- Withdraw Flash-copy relations between the Source and Target  
Date/Time: April 28, 2005 5:04:07 AM GMT-08:00 IBM DSCLI Version: 5.0.3.61 DS: IBM.2107-7505831  
CMUC00140l rmflash: FlashCopy pair 2500:2700 successfully removed.  
CMUC00140l rmflash: FlashCopy pair 2501:2701 successfully removed.  
CMUC00140l rmflash: FlashCopy pair 2502:2702 successfully removed.  
CMUC00140l rmflash: FlashCopy pair 2503:2703 successfully removed.  
CMUC00140l rmflash: FlashCopy pair 2504:2704 successfully removed.  
CMUC00140l rmflash: FlashCopy pair 2505:2705 successfully removed.  
CMUC00140l rmflash: FlashCopy pair 2506:2706 successfully removed.  
CMUC00140l rmflash: FlashCopy pair 2507:2707 successfully removed.  
CMUC00140l rmflash: FlashCopy pair 2508:2708 successfully removed.  
CMUC00140l rmflash: FlashCopy pair 2509:2709 successfully removed.  
CMUC00140l rmflash: FlashCopy pair 250A:270A successfully removed.  
CMUC00140l rmflash: FlashCopy pair 250B:270B successfully removed.  
CMUC00140l rmflash: FlashCopy pair 250C:270C successfully removed.  
CMUC00140l rmflash: FlashCopy pair 250D:270D successfully removed.  
CMUC00140l rmflash: FlashCopy pair 250E:270E successfully removed.  
CMUC00140l rmflash: FlashCopy pair 250F:270F successfully removed.  
CMUC00140l rmflash: FlashCopy pair 2510:2710 successfully removed.  
CMUC00140l rmflash: FlashCopy pair 2511:2711 successfully removed.  
CMUC00140l rmflash: FlashCopy pair 2512:2712 successfully removed.  
CMUC00140l rmflash: FlashCopy pair 2513:2713 successfully removed.  
CMUC00140l rmflash: FlashCopy pair 2514:2714 successfully removed.  
CMUC00140l rmflash: FlashCopy pair 2515:2715 successfully removed.  
CMUC00140l rmflash: FlashCopy pair 2516:2716 successfully removed.  
CMUC00140l rmflash: FlashCopy pair 2517:2717 successfully removed.  
CMUC00140l rmflash: FlashCopy pair 2518:2718 successfully removed.  
CMUC00140l rmflash: FlashCopy pair 2519:2719 successfully removed.  
CMUC00140l rmflash: FlashCopy pair 251C:271C successfully removed.  
CMUC00140l rmflash: FlashCopy pair 251D:271D successfully removed.  
CMUC00140l rmflash: FlashCopy pair 251E:271E successfully removed.  
CMUC00140l rmflash: FlashCopy pair 251F:271F successfully removed.  
CMUC00140l rmflash: FlashCopy pair 2520:2720 successfully removed.  
CMUC00140l rmflash: FlashCopy pair 2521:2721 successfully removed.

real 0m19.33s



## SAP System Cloning Solution using the IBM TotalStorage DS8300

```
user 0m5.12s
sys 0m0.27s
12:04:23-- Withdraw Flash-copy relations between the Source and Target : Successful
12:04:23-- Flash-copy all S01 SAP volumes to B01
Date/Time: April 28, 2005 5:04:26 AM GMT-08:00 IBM DSCLI Version: 5.0.3.61 DS: IBM.2107-7505831
CMUC001371 mkflash: FlashCopy pair 2500:2700 successfully created.
CMUC001371 mkflash: FlashCopy pair 2501:2701 successfully created.
CMUC001371 mkflash: FlashCopy pair 2502:2702 successfully created.
CMUC001371 mkflash: FlashCopy pair 2503:2703 successfully created.
CMUC001371 mkflash: FlashCopy pair 2504:2704 successfully created.
CMUC001371 mkflash: FlashCopy pair 2505:2705 successfully created.
CMUC001371 mkflash: FlashCopy pair 2506:2706 successfully created.
CMUC001371 mkflash: FlashCopy pair 2507:2707 successfully created.
CMUC001371 mkflash: FlashCopy pair 2508:2708 successfully created.
CMUC001371 mkflash: FlashCopy pair 2509:2709 successfully created.
CMUC001371 mkflash: FlashCopy pair 250A:270A successfully created.
CMUC001371 mkflash: FlashCopy pair 250B:270B successfully created.
CMUC001371 mkflash: FlashCopy pair 250C:270C successfully created.
CMUC001371 mkflash: FlashCopy pair 250D:270D successfully created.
CMUC001371 mkflash: FlashCopy pair 250E:270E successfully created.
CMUC001371 mkflash: FlashCopy pair 250F:270F successfully created.
CMUC001371 mkflash: FlashCopy pair 2510:2710 successfully created.
CMUC001371 mkflash: FlashCopy pair 2511:2711 successfully created.
CMUC001371 mkflash: FlashCopy pair 2512:2712 successfully created.
CMUC001371 mkflash: FlashCopy pair 2513:2713 successfully created.
CMUC001371 mkflash: FlashCopy pair 2514:2714 successfully created.
CMUC001371 mkflash: FlashCopy pair 2515:2715 successfully created.
CMUC001371 mkflash: FlashCopy pair 2516:2716 successfully created.
CMUC001371 mkflash: FlashCopy pair 2517:2717 successfully created.
CMUC001371 mkflash: FlashCopy pair 2518:2718 successfully created.
CMUC001371 mkflash: FlashCopy pair 2519:2719 successfully created.
CMUC001371 mkflash: FlashCopy pair 251C:271C successfully created.
CMUC001371 mkflash: FlashCopy pair 251D:271D successfully created.
CMUC001371 mkflash: FlashCopy pair 251E:271E successfully created.
CMUC001371 mkflash: FlashCopy pair 251F:271F successfully created.
CMUC001371 mkflash: FlashCopy pair 2520:2720 successfully created.
CMUC001371 mkflash: FlashCopy pair 2521:2721 successfully created.
```

```
real 0m13.84s
user 0m5.10s
sys 0m0.30s
Date/Time: April 28, 2005 5:04:40 AM GMT-08:00 IBM DSCLI Version: 5.0.3.61 DS: IBM.2107-7505831
CMUC001721 unfreezeflash: FlashCopy consistency group for logical subsystem 25: successfully reset.
```

```
real 0m12.06s
user 0m4.74s
sys 0m0.31s
12:04:49-- Flash-copy all S01 SAP volumes to B01 : Successful
12:04:49-- Resynch S01 archive volume with B01 archive volume
Date/Time: April 28, 2005 5:04:52 AM GMT-08:00 IBM DSCLI Version: 5.0.3.61 DS: IBM.2107-7505831
CMUC001681 resynchflash: FlashCopy volume pair 2521:2721 successfully resynched.
```

```
real 0m18.44s
user 0m4.78s
sys 0m0.34s
12:05:08-- Resynch S01 archive volume with B01 archive volume: Successful
```

12:05:08----- STEP 2 : FLASH-COPY PHASE COMPLETED SUCCESSFULLY -----

## Restore phase log

12:05:08 ----- STEP 3: STARTING RESTORE PHASE -----

```
12:05:08-- Configuring Physical Disks on fcs0
12:05:10-- Configured Physical Disks for fcs0 on crossfire
12:05:10-- Configuring VPATH's on fcs0
12:05:13-- Configured VPATH's for fcs0 on crossfire
12:05:13-- Importing Volume Groups on crossfire
```



## SAP System Cloning Solution using the IBM TotalStorage DS8300

```
B01sap00vg
Varyonvg B01sap00vg - successful on host crossfire
B01sap01vg
Varyonvg B01sap01vg - successful on host crossfire
B01sap02vg
Varyonvg B01sap02vg - successful on host crossfire
B01sap03vg
Varyonvg B01sap03vg - successful on host crossfire
B01sap04vg
Varyonvg B01sap04vg - successful on host crossfire
B01sap05vg
Varyonvg B01sap05vg - successful on host crossfire
B01sap06vg
Varyonvg B01sap06vg - successful on host crossfire
B01sap07vg
Varyonvg B01sap07vg - successful on host crossfire
B01sap08vg
Varyonvg B01sap08vg - successful on host crossfire
B01sap09vg
Varyonvg B01sap09vg - successful on host crossfire
12:06:34-- Importing Volume Groups on crossfire : Successful
12:06:34-- Mounting File Systems on crossfire
Replaying log for /dev/lvora01.
Replaying log for /dev/lvarc03.
Replaying log for /dev/lvarchive.
Replaying log for /dev/lvdata01.
Replaying log for /dev/lvdata02.
Replaying log for /dev/lvdata03.
Replaying log for /dev/lvdata04.
Replaying log for /dev/lvdata05.
Replaying log for /dev/lvsap01.
12:07:15-- Mounting File Systems on crossfire : Successful
12:07:15-- Creating Groups & Users on crossfire
12:07:15-- Check for the group dba on crossfire
12:07:15-- Check for the user oras01 on crossfire
12:07:16-- Check for the user orab01 on crossfire
12:07:16-- Check for the group sapsys on crossfire
12:07:17-- Check for the user s01adm on crossfire
12:07:17-- Check for the user b01adm on crossfire
12:07:19-- Creating Groups & Users on crossfire : Successful
12:07:19-- Changing DB environment variables on crossfire
12:07:22-- Changing DB environment variables on crossfire : Finished
12:07:22-- Editing listener & tnsnames on crossfire
12:07:23-- Editing listener.ora on crossfire : Finished
12:07:24-- Editing tnsnames.ora on crossfire : Finished
12:07:24-- Change Ownership of S01 database on crossfire
12:08:06-- Change Ownership of S01 database on crossfire : Successful
12:08:06-- Start Recovery of S01 Database on crossfire
```

SQL\*Plus: Release 9.2.0.6.0 - Production on Thu Apr 28 12:08:10 2005

Copyright (c) 1982, 2002, Oracle Corporation. All rights reserved.

Connected to an idle instance.

SQL> SQL> ORACLE instance started.

Total System Global Area 3000569160 bytes

Fixed Size 744776 bytes

Variable Size 1560281088 bytes

Database Buffers 1438220288 bytes

Redo Buffers 1323008 bytes

Database mounted.

Database opened.

SQL> ORA-00283: recovery session canceled due to errors

ORA-01124: cannot recover data file 1 - file is in use or recovery

ORA-01110: data file 1: '/oracle/S01/sapdata1/system\_1/system.data1'

SQL> ALTER DATABASE OPEN RESETLOGS

## SAP System Cloning Solution using the IBM TotalStorage DS8300

```
*
ERROR at line 1:
ORA-01531: a database already open by the instance

SQL>
SQL> Disconnected from Oracle9i Enterprise Edition Release 9.2.0.6.0 - 64bit Production
With the Partitioning option
JServer Release 9.2.0.6.0 - Production
12:08:42-- Start Recovery of S01 Database on crossfire : Successful
12:08:42-- Copy control file to USERTRACE DIRECTORY and shutdown Database

SQL*Plus: Release 9.2.0.6.0 - Production on Thu Apr 28 12:08:44 2005

Copyright (c) 1982, 2002, Oracle Corporation. All rights reserved.
```

```
Connected to:
Oracle9i Enterprise Edition Release 9.2.0.6.0 - 64bit Production
With the Partitioning option
JServer Release 9.2.0.6.0 - Production
```

```
SQL>
Database altered.
```

```
SQL> Database closed.
Database dismounted.
ORACLE instance shut down.
SQL> Disconnected from Oracle9i Enterprise Edition Release 9.2.0.6.0 - 64bit Production
With the Partitioning option
JServer Release 9.2.0.6.0 - Production
12:08:48-- Copy control file to USERTRACE DIRECTORY and shutdown Database :Finished
12:08:48-- Copy Control file from TRACE to /oracle/S01/920_64 and Change Ownership on crossfire
12:08:49-- Copy Control file from TRACE to /oracle/S01/920_64 and Change Ownership on crossfire : Finished
12:08:49-- Un-Mounting File Systems on crossfire for S01
/usr/sap/trans:
/usr/sap/S01:
/sapmnt/S01:
/oracle/stage/920_64:
/oracle/client:
/oracle/S01/sapreorg:
/oracle/S01/sapdata5:
/oracle/S01/sapdata4:
/oracle/S01/sapdata3:
/oracle/S01/sapdata2:
/oracle/S01/sapdata1:
/oracle/S01/origlogB:
/oracle/S01/origlogA:
/oracle/S01/oraarch:
/oracle/S01/mirrlogB:
/oracle/S01/mirrlogA:
/oracle/S01/920_64:
/oracle/S01:
/oracle:
12:09:09-- Un-Mount File Systems on crossfire for S01 : Successful
12:09:09-- Change S01 to B01 in /etc/filesystems on crossfire
12:09:11-- Change S01 to B01 in /etc/filesystems on crossfire Successful
12:09:11-- Mounting File Systems on crossfire for B01
12:09:30-- Mounting File Systems on crossfire for B01 : Successful

12:09:30 ----- STEP 3: RESTORE PHASE COMPLETED -----
```

### Clone phase log

```
12:09:30----- STEP 4 : STARTING CLONE PHASE -----

12:09:30-- Edit Controlfile of B01 Database
12:09:32-- Edit Control file of B01 Database :Successful
```



## SAP System Cloning Solution using the IBM TotalStorage DS8300

```
12:09:32-- Change environment profile files for orab01 & b01adm
12:09:32-- Copy environment profiles for the user orab01 on crossfire
12:09:34-- Make Changes to environment variables for the user orab01 on crossfire
12:09:40-- Make Changes to environment variables for the user orab01 on crossfire : Finished
12:09:40-- Copy environment profiles for the user b01adm on crossfire
12:09:42-- Make Changes to environment variables for the user b01adm on crossfire
12:09:48-- Make Changes to environment variables for the user b01adm on crossfire : Finished
12:09:48-- Copy SAP /etc/services from Source to Target
12:09:51-- Copy SAP /etc/services from Source to Target : Successful
12:09:51-- Change environment profile files for orab01 & b01adm :Successful
12:09:51-- Edit LISTENER.ORA of B01 on crossfire
12:09:54-- Edit LISTENER.ORA of B01 on crossfire : Successful
12:09:54-- Edit TNSNAMES.ORA of B01 on crossfire
12:09:56-- Edit TNSNAMES.ORA of B01 on crossfire : Successful
12:09:56-- Edit initialization file initB01.ora on crossfire
12:09:57-- Edit initialization file initB01.ora on crossfire : Successful
12:09:57-- Edit initialization file initB01.dba on crossfire
12:09:59-- Edit initialization file initB01.dba on crossfire : Successful
12:09:59-- Edit initialization file initB01.sap on crossfire
12:10:00-- Edit initialization file initB01.sap on crossfire : Successful
12:10:00-- Change Ownership of B01 database on crossfire
12:10:09-- Change Ownership of B01 database on crossfire : Successful
12:10:09-- Create Oracle Link Libraries for B01 database on crossfire
```

### - Linking Oracle

```
rm -f /oracle/B01/920_64/rdbms/lib/oracle
ld -b64 -o /oracle/B01/920_64/rdbms/lib/oracle -L/oracle/B01/920_64/rdbms/lib/ -L/oracle/B01/920_64/lib/ -bbigtoc -b
noipath -bl:/oracle/B01/920_64/lib/ksms.imp /oracle/B01/920_64/rdbms/lib/opimai.o
/oracle/B01/920_64/rdbms/lib/ssoraed.o /ora
cle/B01/920_64/rdbms/lib/ttcoi.o /oracle/B01/920_64/lib/nautab.o /oracle/B01/920_64/lib/naeet.o
/oracle/B01/920_64/lib/naec
t.o /oracle/B01/920_64/lib/naedhs.o /oracle/B01/920_64/rdbms/lib/config.o -lserver9 /oracle/B01/920_64/lib/libodm9.so -
lskg
xp9 -lskgxn9 -lclient9 -lvs9 -lwtcserver9 -lcommon9 -lgeneric9 /oracle/B01/920_64/rdbms/lib/defopt.o -lknlopt `if /bin/ar
-X64 tv /oracle/B01/920_64/rdbms/lib/libknlopt.a | grep xsyeolap.o > /dev/null 2>&1 ; then echo "-loraolap9 -
bE:/oracle/B01/
920_64/rdbms/lib/olap.exp -bE:/oracle/B01/920_64/rdbms/lib/libamd.exp" ; fi` -lslax9 -lpls9 -lplp9 -
bE:/oracle/B01/920_64/r
dbms/lib/plsqlcomp.exp -lserver9 -lclient9 -lvs9 -lwtcserver9 -lcommon9 -lgeneric9 -lknlopt -lslax9 -lpls9 -lplp9 -lj
ox9 -bE:/oracle/B01/920_64/rdbms/lib/oracle.exp -lwwg9 `sed -e 's/-ljava/g' /oracle/B01/920_64/lib/ldflags` -lncrypt
9 -linsgr9 -lnzjs9 -ln9 -lnl9 -lnzjs9 -lnro9 `sed -e 's/-ljava/g' /oracle/B01/920_64/lib/ldflags` -lncrypt9 -linsgr9 -ln
zjs9 -ln9 -lnl9 -lnzjs9 -lclient9 -lvs9 -lwtcserver9 -lcommon9 -lgeneric9 -lwtcserver9 -lmm -lnls9 -lcore9 -lnls9 -lcor
e9 -lnls9 -lxml9 -lcore9 -lnls9 -lnls9 `sed -e 's/-ljava/g' /oracle/B01/920_64/lib/ldflags` -lncrypt9 -linsgr9 -lnzjs9
-ln9 -lnl9 -lnzjs9 -lnro9 `sed -e 's/-ljava/g' /oracle/B01/920_64/lib/ldflags` -lncrypt9 -linsgr9 -lnzjs9 -ln9 -lnl9
-lnzjs9 -lclient9 -lvs9 -lwtcserver9 -lcommon9 -lgeneric9 -lpls9 -ltrace9 -lnls9 -lcore9 -lnls9 -lcore9 -lnls9 -lxml9 -lc
ore9 -lnls9 -lnls9 -lserver9 `if /bin/ar -X64 tv /oracle/B01/920_64/rdbms/lib/libknlopt.a | grep "kxmnsd.o" > /dev/null 2>&1
; then echo " " ; else echo "-lordsd9"; fi` -lctxc9 -lctx9 -lzx9 -lgx9 -lctx9 -lzx9 -lgx9 -lordimt9 -lnls9 -lcore9 -lnls9
-lcore9 -lnls9 -lxml9 -lcore9 -lnls9 -lnls9 -lnls9 -lnls9 -lnls9 -lnls9 -lnls9 -lnls9 -lnls9 -lnls9 -lnls9 -lnls9 -lnls9
-bE:/oracle/B01/920_64/rdbms/lib/libcorejava.exp -lld -lm `
cat /oracle/B01/920_64/lib/sysliblist` -lm `if [ "\usr/bin/uname -v" = "4" ]; \
then echo "-bl:/oracle/B01/920_64/lib/pw-syscall.exp"; fi; `if /bin/ar -X64 t /oracle/B01/920_64/rdbms/lib/libknlop
t.a | grep '^kcms.o' > /dev/null 2>&1 ; then echo "-lha_gs64_r -lha_em_r"; fi` -locijdbcst9 -lxs9
mv -f /oracle/B01/920_64/bin/oracle /oracle/B01/920_64/bin/oracleO
mv /oracle/B01/920_64/rdbms/lib/oracle /oracle/B01/920_64/bin/oracle
chmod 6751 /oracle/B01/920_64/bin/oracle
12:10:40-- Create Oracle Link Libraries for B01 database on crossfire : Successful
12:10:40-- Delete Old Control Files crossfire
12:10:42-- Deleting Old Control Files on crossfire: Successful
12:10:42-- Start Oracle with B01 SID
```

SQL\*Plus: Release 9.2.0.6.0 - Production on Thu Apr 28 12:10:44 2005

Copyright (c) 1982, 2002, Oracle Corporation. All rights reserved.

Connected to an idle instance.

SQL> ORACLE instance started.

Total System Global Area 3000569160 bytes  
Fixed Size 744776 bytes



## SAP System Cloning Solution using the IBM TotalStorage DS8300

Variable Size 1560281088 bytes  
Database Buffers 1438220288 bytes  
Redo Buffers 1323008 bytes

Control file created.

SQL>  
Database altered.

SQL> Disconnected from Oracle9i Enterprise Edition Release 9.2.0.6.0 - 64bit Production  
With the Partitioning option  
JServer Release 9.2.0.6.0 - Production  
12:10:55-- Start Oracle with B01 SID : Successful  
12:10:55-- Start Listener with B01 SID

LSNRCTL for IBM/AIX RISC System/6000: Version 9.2.0.6.0 - Production on 28-APR-2005 12:10:58

Copyright (c) 1991, 2002, Oracle Corporation. All rights reserved.

Starting /oracle/B01/920\_64/bin/tnslsnr: please wait...

TNSLSNR for IBM/AIX RISC System/6000: Version 9.2.0.6.0 - Production  
System parameter file is /oracle/B01/920\_64/network/admin/listener.ora  
Log messages written to /oracle/B01/920\_64/network/log/listener.log  
Listening on: (DESCRIPTION=(ADDRESS=(PROTOCOL=ipc)(KEY=B01.WORLD)))  
Listening on: (DESCRIPTION=(ADDRESS=(PROTOCOL=ipc)(KEY=B01)))  
Listening on: (DESCRIPTION=(ADDRESS=(PROTOCOL=tcp)(HOST=crossfire.storage.sanjose.ibm.com)(PORT=1527)))

Connecting to (ADDRESS=(PROTOCOL=IPC)(KEY=B01.WORLD))  
STATUS of the LISTENER

```
-----
Alias                LISTENER
Version              TNSLSNR for IBM/AIX RISC System/6000: Version 9.2.0.6.0 - Production
Start Date           28-APR-2005 12:10:59
Uptime               0 days 0 hr. 0 min. 2 sec
Trace Level          off
Security             OFF
SNMP                 OFF
Listener Parameter File /oracle/B01/920_64/network/admin/listener.ora
Listener Log File    /oracle/B01/920_64/network/log/listener.log
Listening Endpoints Summary...
  (DESCRIPTION=(ADDRESS=(PROTOCOL=ipc)(KEY=B01.WORLD)))
  (DESCRIPTION=(ADDRESS=(PROTOCOL=ipc)(KEY=B01)))
  (DESCRIPTION=(ADDRESS=(PROTOCOL=tcp)(HOST=crossfire.storage.sanjose.ibm.com)(PORT=1527)))
Services Summary...
Service "B01" has 1 instance(s).
  Instance "B01", status UNKNOWN, has 1 handler(s) for this service...
The command completed successfully
12:11:00-- Start Listener with B01 SID : Successful
12:11:00-- Create OPSB01ADM user on B01 database
```

SQL\*Plus: Release 9.2.0.6.0 - Production on Thu Apr 28 12:11:02 2005

Copyright (c) 1982, 2002, Oracle Corporation. All rights reserved.

Connected to:  
Oracle9i Enterprise Edition Release 9.2.0.6.0 - 64bit Production  
With the Partitioning option  
JServer Release 9.2.0.6.0 - Production

SQL>  
User created.

SQL>  
User created.

SQL>  
Grant succeeded.

## SAP System Cloning Solution using the IBM TotalStorage DS8300

SQL>  
Grant succeeded.

SQL>  
Table created.

SQL>  
User dropped.

SQL>  
User dropped.

SQL> Disconnected from Oracle9i Enterprise Edition Release 9.2.0.6.0 - 64bit Production  
With the Partitioning option  
JServer Release 9.2.0.6.0 - Production  
12:11:06-- Create OPS\$B01ADM user on B01 database : Successful

12:11:06----- STEP 4 : CLONE PHASE COMPLETED SUCCESSFULLY -----

### Post Copy Phase log

12:11:06----- STEP 5 : STARTING POST-COPY PHASE -----

12:11:06-- Creating SAP links on crossfire  
12:11:09-- Creating SAP links on crossfire : Successful  
12:11:09-- Change SAP profile parameters on crossfire  
12:11:09-- Edit B01 instance profile to comment out batch processes  
12:11:12-- Edit B01 instance profile to comment out batch processes : Successful  
12:11:12-- Change SAP B01 profiles to B01 profiles  
12:11:14-- S01 DEFAULT.PFL is changed to B01 DEFAULT.PFL  
12:11:16-- S01\_DVEBMGS00\_spyder is changed to B01\_DVEBMGS00\_crossfire  
12:11:19-- START\_DVEBMGS00\_spyder is changed to START\_DVEBMGS00\_crossfire  
12:11:19-- Change B01 profiles to B01 profiles : Successful  
12:11:19-- Change SAP profile parameters on crossfire : Successful  
12:11:19-- Change Ownership on SAP File Systems on crossfire  
12:11:21-- Change Ownership on SAP File Systems on crossfire : Successful  
12:11:21-- Change RFC destination, delete spool requests & their lists on crossfire  
12:11:21-- Change RFC destination, delete spool requests & their lists on crossfire : Successful  
12:11:21-- Start SAP on crossfire

Checking B01 Database

-----  
Database is running

Starting SAP-Collector Daemon

\*\*\*\*\*  
\* This is Saposcol Version COLL 20.86 620 - AIX v4.20 5L-64 bit 040309  
\* Usage: saposcol -l: Start OS Collector  
\* saposcol -k: Stop OS Collector  
\* saposcol -d: OS Collector Dialog Mode  
\* saposcol -s: OS Collector Status  
\* Starting collector (create new process)

\*\*\*\*\*  
/usr/sap/tmp/dev\_coll moved to /usr/sap/tmp/dev\_coll.old  
saposcol on host crossfire started

Checking B01 Database

-----  
Database is running

Starting SAP Instance DVEBMGS00

-----  
Startup-Log is written to /home/b01adm/startsap\_DVEBMGS00.log  
Instance on host crossfire started

12:12:05-- Start SAP on crossfire: Successful -- Apply License manually

12:12:05----- STEP 5: POST-COPY PHASE COMPLETED SUCCESSFULLY -----

## 10. Post cloning observations

The following screen capture appears after post cloning activities are performed on the cloned system, such as when we run SAP transaction “sick”. This is the result of the batch jobs parameter in the profile being changed to “0”. Hence it is not an error.

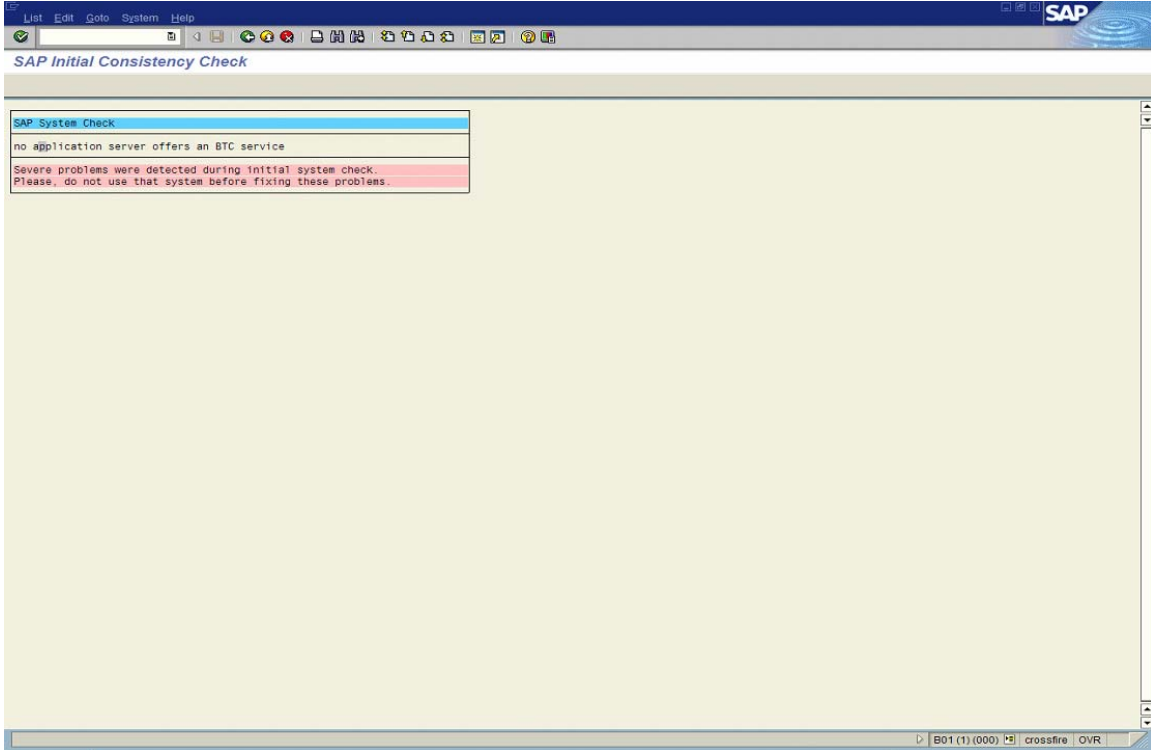

## References

- 1) IBM TotalStorage DS8000 Series: Concepts and Architecture - IBM Document Number: SG24-6452-00 <http://www.redbooks.ibm.com/>
- 2) IBM Enterprise Storage Server - IBM Document Number: SG24-5465-00 <http://www.redbooks.ibm.com/>
- 3) ESS Layout Considerations for a Heterogeneous System Landscape - Dr. Jens Claussen, SAP Advanced Technology Group, December 2000 [Presentation]
- 4) SAP R/3 Storage Management - Split Mirror Backup Recovery on IBM's Enterprise Storage Server (ESS) - Siegfried Schmidt, SAP AG, Advanced Technology Group, February 2000, <http://service.sap.com/split-mirror> or <http://www.storage.ibm.com/hardsoft/diskdrls/technology.htm>
- 5) Fundamentals of Database Layout SAP AG, Version 2.0 August 2000 <http://service.sap.com/atg> -> DB & Storage Layouts
- 6) Oracle 8i Backup & Recovery Handbook - Rama Velpuri and Anand Adkoli, Oracle Press, Osborne McGraw Hill, 2001
- 7) SSQJ Documentation Version 9.B – SAP Advanced Technology Group. <http://service.sap.com/atg>
- 8) Storage Management for SAP and DB2 UDB: Split Mirror Backup / Recovery With IBM's Enterprise Storage Server (ESS) - Sanjoy Das, Siegfried Schmidt, Jens Claussen, BalaSanni Godavari, August 2001, <http://service.sap.com/split-mirror> or <http://www.storage.ibm.com/hardsoft/diskdrls/technology.htm>
- 9) Storage Management for SAP and Oracle: Split Mirror Backup / Recovery With IBM's Enterprise Storage Server (ESS) - Sanjoy Das, Siegfried Schmidt, Peter Pitterling, BalaSanni Godavari, October 2001 <http://service.sap.com/split-mirror> or [www.storage.ibm.com/hardsoft/products/sap/splitmirror-oracle.pdf](http://www.storage.ibm.com/hardsoft/products/sap/splitmirror-oracle.pdf)
- 10) Storage Management for SAP and Oracle8i on SUN SOLARIS: Split Mirror Backup / Recovery With IBM's Enterprise Storage Server (ESS) - Sanjoy Das, Siegfried Schmidt, Sathees Kodi, Bala Sanni Godavari, June, 2002, <http://service.sap.com/split-mirror>.
- 11) Consistency Technology for mySAP Business Suite – Creating Consistent Images of a Distributed System Landscape With IBM's Enterprise Storage Server (ESS)