

# Split Mirror Backup / Recovery Solution with the IBM TotalStorage DS8000 Series

## CONTENTS

Abstract	4
1. Introduction	5
2. Customer Requirements	6
3. Introduction to the IBM TotalStorage DS8000 series	7
4. DS8000 Architecture	9
5. Advanced Copy Services:	11
6. Installation Preparations and Lab Setup	12
7. SAP / Oracle Database Layout	14
8. Split Mirror Backup and Recovery Process	15
Phase Description of the SMBR Backup Process:	16
Appendix	23
9. Sample Scripts	23
10. Input Config Files	28
11. Hardware used	32
12. Software used	33
13. Logs	34
References	44

## Split Mirror Backup / Recovery Solution with the IBM TotalStorage DS8000 Series

The following terms are trademarks of International Business Machines Corporation in the United States, other countries, or both:

AIX®, DB2 Universal Database®, Enterprise Storage Server (ESS)®, FlashCopy®, IBM TotalStorage Server DS6000®, Tivoli®

The following terms are trademarks of SAP AG in Germany, in the United States, other countries, or both:

SAP®, SAP Logo®, mySAP.com®, R/3®, ABAP®, SSQJ®, Advanced Technology Group®, OSS®, SAP R/3 Note®

The following terms are trademarks of Oracle Corporation in the United States, other countries, or both:

ORACLE®

The information provided in this document is distributed "AS IS" basis without any warranty either express or implied. IBM AND SAP DISCLAIM ALL EXPRESS AND IMPLIED WARRANTIES WITH RESPECT TO SUCH INFORMATION, INCLUDING ANY WARRANTIES OF MERCHANTABILITY OR FITNESS FOR A PARTICULAR PURPOSE. The use of this information or the implementation of any of these techniques is a customer responsibility and depends on the customer's ability to evaluate and integrate them into their operating environment. While the information contained in this paper has been reviewed by IBM and SAP for accuracy, there is no guarantee that the same or similar results will be obtained elsewhere. Customers attempting to adapt these techniques to their own environments do so at their own risk. The performance data contained herein was obtained in a controlled environment based on the use of specific data. Actual results that may be obtained in other operating environments may vary significantly. These values do not constitute a guarantee of performance.

References in this document to IBM and SAP products, programs, or services do not imply that IBM or SAP intend to make such products available in all countries in which each company operates. Neither IBM nor SAP warrants the others products. Each company's products are warranted in accordance with the agreements under which they are provided.

Version: 1.4  
June 23, 2005

Document Author:  
Sathees B Kodi/San Jose/IBM  
E-Mail: [satheesk@us.ibm.com](mailto:satheesk@us.ibm.com)  
Ph: 1-408-256-3065 (T/L: 276-3065)

Document Owner:  
Amit Mathur/San Francisco/IBM  
E-Mail: [amitmat@us.ibm.com](mailto:amitmat@us.ibm.com)  
Ph: 1-408-256-9932 (T/L: 276-9932)



## Abstract

This white paper explores the use of an IBM TotalStorage DS8000 series storage server as an essential component of advanced infrastructure solutions, such as one implementing a High Availability Split Mirror Backup / Recovery (SMBR) solution for SAP<sup>®</sup> R/3<sup>®</sup> on the Oracle RDBMS and the AIX operating system environments.

It sets forth a methodology for a “zero” downtime backup of SAP databases used in the above SMBR environment. This solution is illustrated on an IBM TotalStorage DS8300 IBM’s recently announced enterprise class storage server and uses Advanced Copy functions to demonstrate a “no impact”, server-less backup of a live SAP R3 system without loss of transactions in flight when backing up data.

“Near Instant” availability of a point-in-time copy of an SAP production database using Oracle’s HOT BACKUP feature and IBM’s consistency group technology provides the ability to deliver a global consistent copy of the database using the log information written during the online backup. The ability to provide consistent copies of the database provides flexibility to place an emergency system at the users disposal while recovering the live database from a disaster. Beyond Backup / Recovery, a consistent copy of the database may be used for various purposes, such as creation of a reporting, rroduction-fix or a repository instance for a system running SAP<sup>®</sup> Business Information Warehouse ( SAP BW) system.

## 1. Introduction

SAP's Advanced Technology Group (ATG) has developed split mirror scenarios, using live databases that constantly copy or mirror data using storage subsystems, supporting continuous operation during the split (and resynchronization) of the mirror.

This innovative solution demonstrates how customers can use split mirror backup to perform an online backup of Oracle database while avoiding downtime using IBM Metro Mirror (Formerly known as Peer to Peer Remote Copy (PPRC) in Synchronous mode). This Split Mirror Backup solution also uses the IBM Consistency Group technology in which all writes are suspended simultaneously to provide a global consistent copy as a backup. This paper describes in detail how the SAP R/3 Split Mirror solution can be implemented on the DS8300 using SAP R/3 Enterprise / Oracle 9i / AIX 5L platform. A solution similar to the one described in the following pages was implemented on an IBM ESS with SAP R/3 on Oracle / AIX and was first demonstrated in December 2000.

The importance and the value of this Split Mirror Backup solution is that customer backups can be done in a few minutes instead of the typical long hours without this Split Mirror Backup solution. The whole process will be done in few minutes. This Split Mirror Backup solution is automated through shell scripts and user needs to provide the input values to the environment config file and data config file giving more flexibility to the customers. This Split Mirror Backup solution takes the advantage of Oracle hot backup methodology and copy services functions like FlashCopy with freeze option using consistency group technology.

The Split Mirror Backup solution discussed in the whitepaper was implemented with a dual DS8300 configuration using the DS8000's advanced functions – the local copy function FlashCopy (FC) and the IBM Remote mirror and copy (Also known as metro mirror). The core SAP R/3 system was loaded using a tool developed by SAP - SSQJ to simulate online transactions.

## 2. Customer Requirements

The latest trend towards very large databases (VLDB), accompanied by the need for high availability in a global enterprise environment means that customers now demand production systems are available on a 24 x 7 basis. This also means that in case of a disaster, the system has to be available within minutes or hardly longer than the time needed for the physical reload of the database from secondary or remote storage media. The high availability requirement also implies that backup and the creation of an emergency system may not cause any downtime of the live production system. Finally all procedures to achieve this must be automated.

### 3. Introduction to the IBM TotalStorage DS8000 series

The IBM Total Storage DS8000 series is designed to be a high performance, high-capacity series of disk storage for business critical enterprise storage work loads. It is designed to support 24x7 operations. The DS8000 models use IBM POWER5<sup>®</sup> server technology (with IBM Virtualization Engine technology) and consists of a storage device and either one or two management consoles, two being the recommended configuration. The graphical user interface (GUI) or command-line interface (CLI) allows users to logically partition the storage, monitor I/O performance, and use the built in Copy Services functions

The DS8000 series is designed to provide high performance, connectivity and reliability allowing the workload to be consolidated into a single storage subsystem.

The following list provides an overview of some of features associated with the DS8000 series that allows it to address the customer requirements for performance and reliability.

#### **POWER5 processor technology:**

The DS8000 features IBM's latest POWER5 technology.

#### **Industry-standard fibre channel disk drives:**

The DS8000 series supports a selection of fibre channel disk drives, including 300 GB drives, allowing a DS8100 to scale up to 115.2 TB of capacity and a DS8300 to scale up to 192 TB of capacity.

#### **Four-port fibre channel/FICON adapters:**

New adapters are designed to not only enhance connectivity, but increase configuration flexibility because the individual ports can be configured to support fibre channel or FICON.

#### **New processor memory offerings:**

The DS8100 offers up to 128 GB of processor memory and the DS8300 offers up to 256 GB of processor memory. In addition, the Non-Volatile Storage (NVS) scales to the processor memory size selected, which can also help improve performance. Improved caching algorithms can also help enhance performance versus the ESS Model 800 through new technologies for managing cache space.

#### **More host attachments than the IBM TotalStorage Enterprise storage server Model 800:**



The DS8100 offers up to 16 host adapters and the DS8300 offers up to 32 host adapters. This can be an intermix of ESCON and fibre channel/FICON adapters, further increasing your ability to share your disk storage.

**New internal fabric:**

The DS8000 series features a new internal fabric which can help provide increased bandwidth and fault tolerant internal interconnection, which is also used in the IBM pSeries® Server. It is called RIO-2 (Remote I/O) and can operate at speeds up to 1 GHz and offers a 2 GB per second sustained bandwidth per link.

**High availability:**

The DS8000 series is designed and implemented with component redundancy to help avoid many potential single points of failure.

**Functional enhancements for flexibility and ease-of-use**

The DS8000 series offers functional enhancements and new capabilities that are designed to increase flexibility and usability.

**Logical Unit Number (LUN) and volume management**

- Non-disruptive LUN and volume creation and deletion is now supported. When a LUN or volume is deleted, the capacity can be re-formatted and re-used.
- LUNs and volumes can be configured to span arrays. Therefore, the size of the volume/LUN is not constrained by the size of the array. LUNs up to 2 TB are supported. CKD volumes up to 65,520 cylinders are supported.

**Addressing capabilities:**

More Logical Subsystems (LSS), logical devices, and logical paths can be defined versus the current DS8000.

- Up to 256 LSS
- Up to 65,280 logical devices
- Up to 130,560 FICON logical paths (512 logical paths per control unit image)
- Up to 8,000 procDS8000 logins (509 per SCSI-FCP port)

## 4. DS8000 Architecture

The DS8000 series architecture consists of two processor complexes as shown in Figure-1. Each processor complex has access to multiple host adapters to connect to channel, FICON and ESCON hosts. Each DS8000 series system can potentially have up to 32 host adapters. To access the disk subsystem, each complex uses several four port fibre-channel arbitrated loop (FC-AL) device adapters. A DS8000 series system can potentially have up to sixteen of these adapters arranged into eight pairs. Each adapter connects the complex to two separate switched fibre channel networks. Each switched network attaches disk enclosures that each contains up to 16 disks. Each enclosure contains two 20 port fibre channel switches. Of these 20 ports, 16 are used to attach to the 16 disks in the enclosure and the remaining four are used to either interconnect with other enclosures or to the device adapters. Each disk is attached to both switches. Whenever the device adapter connects to a disk, it uses a switched connection to transfer data. This means that all data travels via the shortest possible path.

The attached hosts interact with software which is running on the complexes to access data on logical volumes. Each complex will host at least one instance of this software (which is called a *server*), which runs in a logical partition (an LPAR). The servers manage all read and write requests to the logical volumes on the disk arrays. During write requests, the servers use fast-write where the data is written to volatile memory on one complex and persistent memory on the other complex. The server then reports the write as complete before it has been written to disk. This provides much faster write performance. Persistent memory is also called NVS or non-volatile storage.

When a host performs a read operation, the servers fetch the data from the disk arrays via the high performance switched disk architecture. The data is then cached in volatile memory in case it is required again. The servers attempt to anticipate future reads by an algorithm known as SARC (Sequential pre-fetching in Adaptive Replacement Cache). Data is held in cache as long as possible using this smart algorithm. If a cache hit occurs where requested data is already in cache, then the host does not have to wait for it to be fetched from the disks.

Both the device and host adapters operate on a high bandwidth fault-tolerant interconnect known as the RIO-G. The RIO-G design allows the sharing of host adapters between servers and supports exceptional performance and reliability.

The Figure -1 below shows the colors as indicators of how the DS8000 hardware is shared between the servers (the cross hatched color is green and the lighter color is yellow). On the left hand side, the green server is running on the left hand processor complex. The green server uses the N-way SMP of the complex to perform its operations. It records its write data and caches its read data in the



volatile memory of the left hand complex. For fast write data it has a persistent memory area on the right hand processor complex. To access the disk arrays under its management (the disks also being pictured in green), it has its own device adapter (again in green). The yellow server on the right operates in an identical fashion. The host adapters (in dark red) are deliberately not colored green or yellow because they are shared between both servers. For complete details on DS8000 architecture please refer IBM Red Book “The IBM TotalStorage DS8000 Series: Concepts and Architecture” (SG24-6452-00).

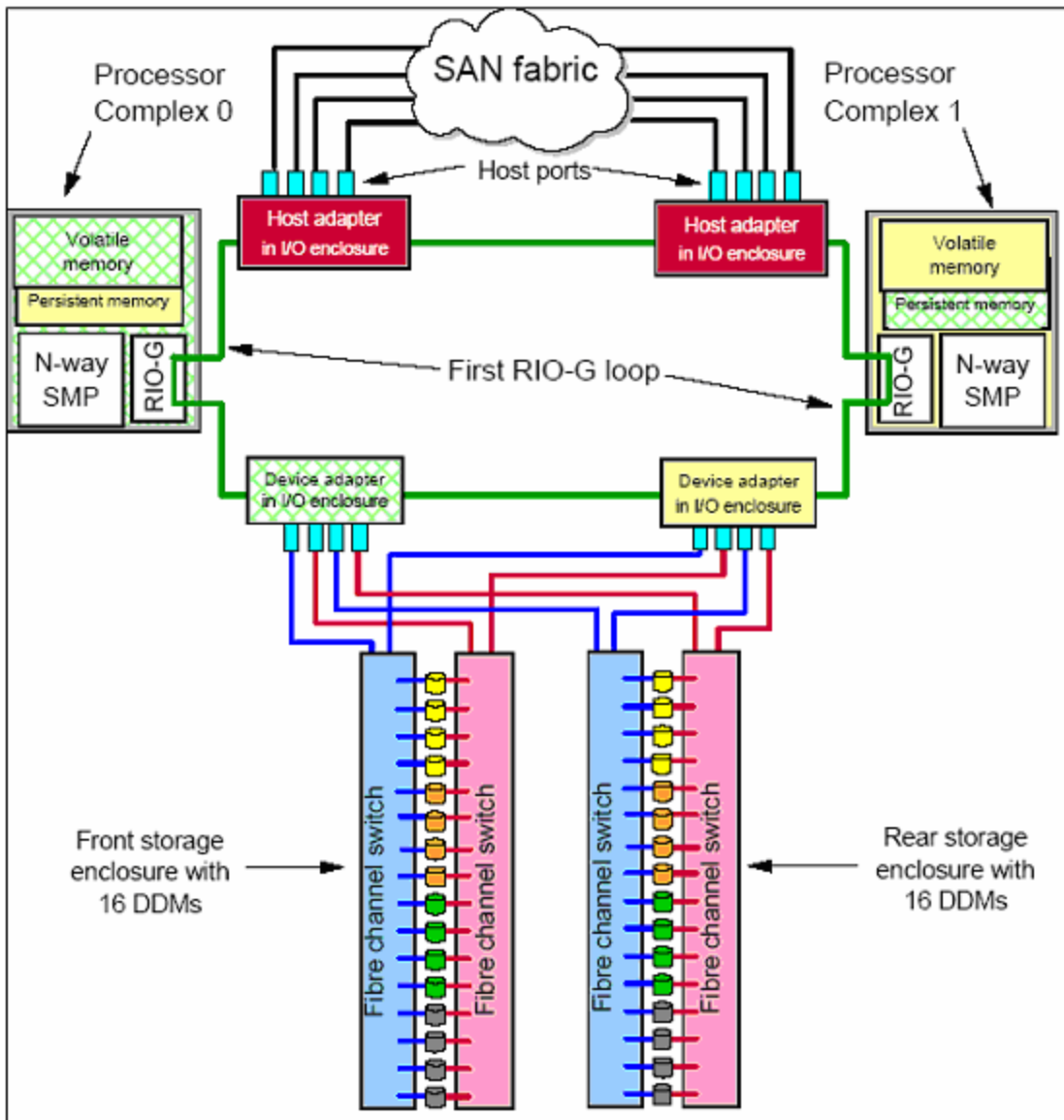

Figure-1

## 5. Advanced Copy Services:

Copy Functions run on DS8000 series storage units and support open systems and zSeries environments. These functions are supported also on the previous generation of storage systems called the IBM TotalStorage Enterprise Storage Server (ESS).

Many design characteristics of the DS8000 and data copying and mirroring capabilities of Advanced Copy Functions features contribute to the protection of your data. The licensed features included in Copy Services are the following:

FlashCopy, which is a Point-in-Time Copy function

Remote Mirror and Copy functions, previously known as Peer-to-Peer Remote Copy or PPRC, which include:

- IBM TotalStorage Metro Mirror, previously known as Synchronous PPRC
- IBM TotalStorage Global Copy, previously known as PPRC Extended Distance
- IBM TotalStorage Global Mirror, previously known as Asynchronous PPRC
- z/OS Global Mirror, previously known as Extended Remote Copy (XRC)
- z/OS Metro/Global Mirror.

### Consistency Group Technology

IBM's Consistency Group Technology supports the consistency between any set of source and target volumes defined in a Consistency group for local copy within a storage system or remote mirror and copy between storage systems. The split mirror backup solution uses the consistency technology at FlashCopy level as well as at remote mirror and Copy level. With Copy Functions, you can create *Consistency Groups* for FlashCopy and PPRC. Consistency Group is a function to keep *data consistency* in the backup copy. Data consistency means that the order of dependent writes is kept in the copy. For more details on the Consistency Group technology refer to the IBM Red Book "IBM TotalStorage Enterprise Storage Server Implementing ESS Copy Services in Open Environments."

### PPRC Consistency Groups

To maintain consistency of data across volumes at the recovery (target) site, volumes in a remote mirror and copy relationship can be collected into a *PPRC Consistency Group*. A PPRC consistency group is a set of volume pairs that have the same primary and secondary LSS for which the PPRC Consistency Group option has been activated.

### Consistency Group FlashCopy



If a consistent point-in-time copy across many logical volumes is required, and the user does not wish to quiesce host I/O or database operations, then the user may use the Consistency Group FlashCopy function to create a consistent copy across multiple logical volumes in multiple storage units.

In order to create this consistent copy, the user would issue a set of Establish FlashCopy commands with a *freeze* option, which will hold off host I/O to the source volumes. In other words, the Consistency Group FlashCopy function provides the capability to temporarily queue (at the host I/O level, not the application level) subsequent write operations to the source volumes that are part of the Consistency Group. During the temporary queuing, the FlashCopy establish is completed. The temporary queuing continues until this condition is reset by the “*unfreezeflash*” command or the time-out value expires (the default is two minutes).

## 6. Installation Preparations and Lab Setup

This section is used describe the initial setup and activities associated with creation of the environment required for this project.

The production host (AIX LPAR) name is “host-a”. The Backup host name is “host-b”. The two hosts are connected to the both DS8300s as shown in Figure 2. These two hosts are connected to these storage servers through SAN switch using Fibre cables. The primary DS8300 server name is OSLSQ04. The secondary or backup DS8300 server name is OSLSQ05. The metro mirror also known as PPRC synchronous mirroring relationship is established between these two DS8300s and PPRC paths connected using fibre cables. In the lab setup only one PPRC path is used for this Split Mirror Backup solution.

The host system operating software used in this solution is AIX 5L (5.2.0.0) and application software used is SAP R/3 Enterprise with Oracle 9i. The tool used to create load simulation on the SAP system is SSQJ 9.C that is designed by SAP. SSQJ is a generic test measurement tool that was developed with ABAP/4 and function modules in core SAP R/3.

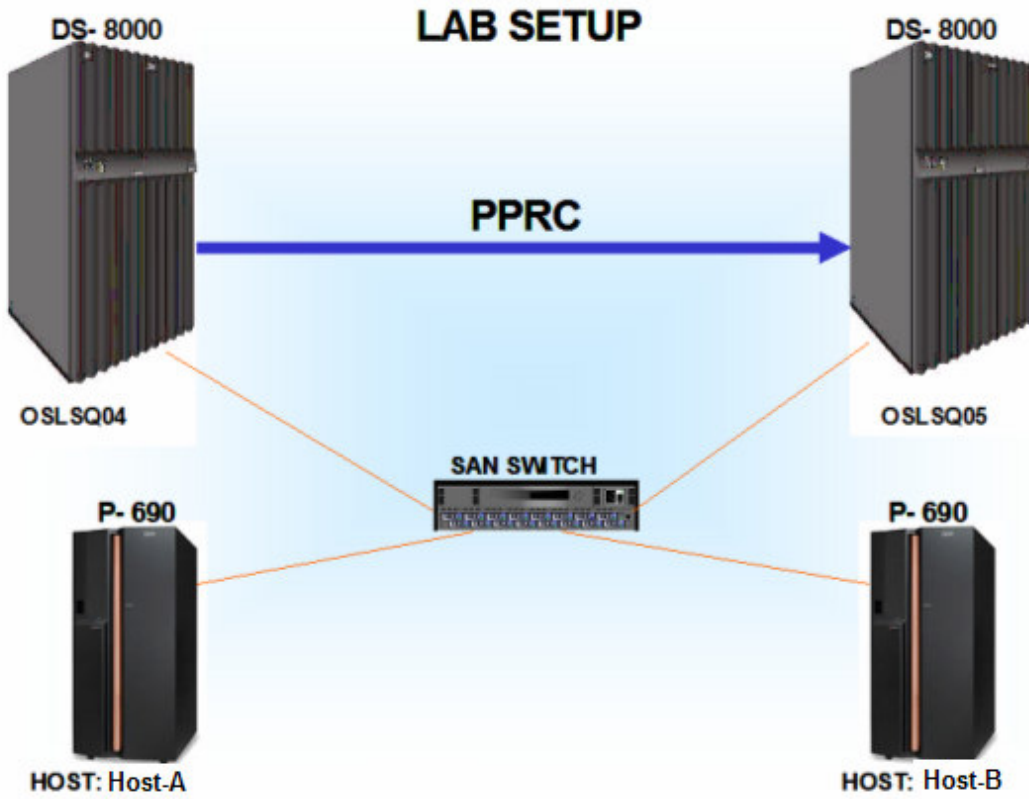

Figure 2

## 7. SAP / Oracle Database Layout

The SAP and Oracle file systems used in this Split Mirror Backup solution is depicted in the following table as shown below. The LUN sizes used are 1 GB, 2 GB, 5 GB, 10 GB, 20 GB, 40GB and 60GB. The LUNs on a DS8300 can be created across the ranks from a single extent pool. This gives more potential flexibility and performance benefit to the customers. It is preferable to have the file system /oracle/S01/oraarch on a separate disk (LUN) in order to re-sync the archive log files in the hot backup process. The disk group S01sap07vg (File system /oracle/S01/sapdata5) is created to store SSQJ tablespaces. Figure 3 below provides the information on SAP and Oracle disk groups, File systems and LUN sizes and their functions.

Disk Group	File System Name	Function	LUN# / Range	File System Size
S01sap00vg	/usr/sap/S01	work & global directory	101C-101E	5 GB
	/sapmnt/S01	SAP executables		2 GB
	/usr/sap/trans	Transport Directory		10 GB
S01sap01vg	/oracle/S01/origlogA	Online redo log files set I	100C-1010	512 MB
	/oracle/S01/mirrlogB	Online redo log files set II		512 MB
	/oracle/S01/mirrlogA	Mirror of origlogA files		512 MB
	/oracle/S01/origlogB	Mirror of origlogB files		512 MB
	/oracle/S01/sapreorg	Temporary data staging		2 GB
S01sap02vg	/oracle	Oracle base directory	1011, 101F-1023	256 MB
	/oracle/client	Oracle Client		512 MB
	/oracle/S01	Oracle Instance specific directory		3 GB
	/oracle/S01/920_64	Oracle Executables		4 GB
	/oracle/stage/920_64	Oracle Staging Area		2.5 GB
S01sap03vg	/oracle/S01/sapdata1	SAP R/3 data files	102C, 1012	30 GB
S01sap04vg	/oracle/S01/sapdata2	SAP R/3 data files	102D, 1013	30 GB
S01sap05vg	/oracle/S01/sapdata3	SAP R/3 data files	102E,103C 103E,1040, 1041	60 GB
S01sap06vg	/oracle/S01/sapdata4	SAP R/3 data files	1038,1039, 103D,103F	80 GB
S01sap07vg	/oracle/S01/sapdata5	SAP R/3 data files	1088 -1089	80 GB
S01sap08vg	/oracle/S01/oraarch	Archive log files	102F-1030	40 GB

Figure 3



## 8. Split Mirror Backup and Recovery Process

Initially the production system is in normal READ/WRITE operation state. In the lab all volumes (Data & Log) are in sync, which are in a constant metro mirror relationship (synchronous PPRC) between source DB<sub>A</sub> and target DB<sub>B</sub> across the primary DS8000 and secondary DS8000 as shown below in Figure 4. This allows the secondary site to be up-to-date at any point of time. The following SMBR scenario is tested in the lab.

The entire process is automated through shell scripts. The scripts are very simplified, and customizations are limited to customers having to fill the environment config file and data config file. One main script can run the whole split mirror process and will complete the local safety FlashCopy target and remote FlashCopy target at secondary server.

### Split Mirror Backup and Recovery and Standby SAP R/3 System

The SMBR process steps are listed below:

The typical split mirror backup and recovery process is shown in Figure 4. In this Split Mirror Backup solution FlashCopy consistency groups with freeze option is used along with Oracle Hot Backup methodology to make global consistent copy.

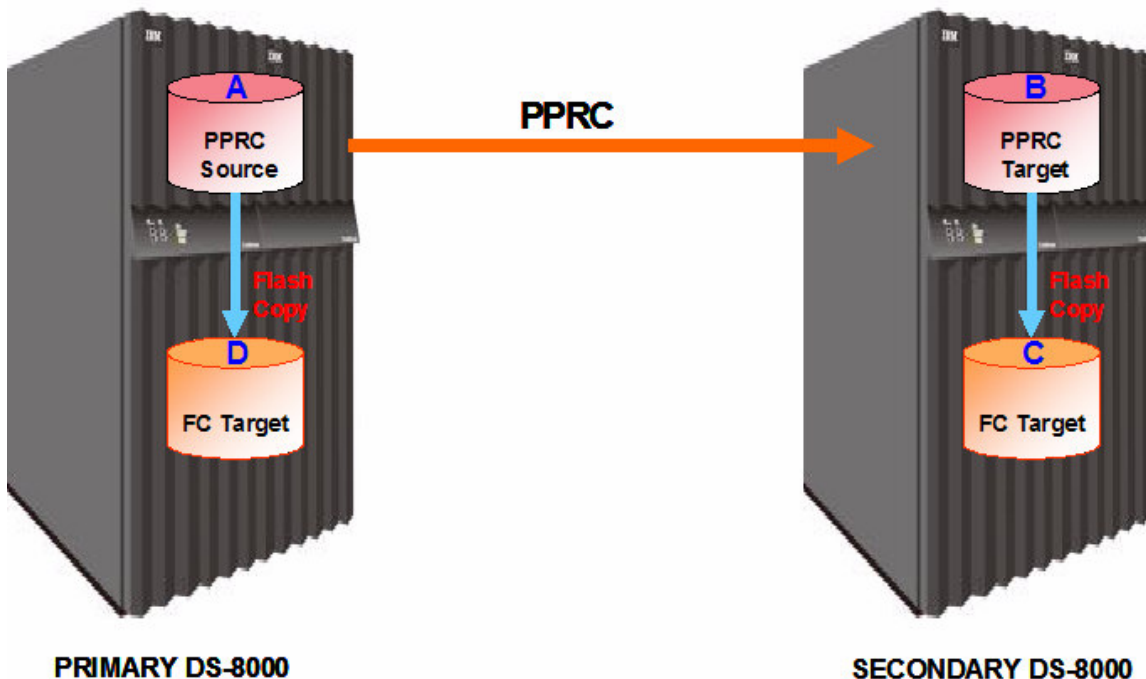

Figure 4

DB<sub>C</sub> volumes have been used to bring up an SAP instance after successful backup to tape. Using the SAP R/3 Homogeneous System Copy procedures for post copy BASIS administration tasks such as changing the RFC settings, locking user IDs, TMS setup and batch job cancellations etc., will confirm that the actual production related activities are deactivated in the test SAP instance on DB<sub>C</sub> volumes.

The first step in SMBR process would be to logoff all the users from the production-fix / reporting / standby instance i.e. DB<sub>C</sub> (on the backup (target) host) before stopping respective SAP and Oracle processes. The SAP / Oracle instance on the Safety FlashCopy target volumes DB<sub>D</sub> in the primary ESS is also stopped.

### **Phase Description of the SMBR Backup Process:**

The scripts are divided into various phases to make scripts user friendly for the customers.

#### **1. Begin Phase:**

1. Establish pprc path from DB<sub>A</sub> to DB<sub>B</sub> and ensure status as 'Full Duplex'.
2. Stop SAP, Database and Listener processes on Host connected to DB<sub>C</sub>.
3. Unmount the filesystems, Vary off the volume groups, Export volume groups and remove devices on target host connected to data volumes DB<sub>C</sub>.

#### **2. FlashCopy Phase on Primary DS8000:**

1. Withdraw Prior FlashCopy (FC) relation between DB<sub>A</sub> and DB<sub>D</sub>
2. Unmount the filesystems, Vary off the volume groups, Export volume groups and delete all previously existing disk groups on DB<sub>C</sub>.
3. Alter Tablespace Begin Backup on DB<sub>A</sub>; Suspend the Database.
4. FlashCopy Data volumes DB<sub>A</sub> to DB<sub>D</sub> (Safety Copy).
5. Unfreeze the FlashCopy source volumes DB<sub>A</sub> to DB<sub>D</sub>.
6. Alter database Resume; on DB<sub>A</sub> Database.
7. Alter Tablespace End Backup; on DB<sub>A</sub> Database.
8. Alter system archive log current; on DB<sub>A</sub> Database.
9. Alter database backup controlfile 'where archive log are located'; on DB<sub>A</sub> Database.
10. Alter system archive log current; on DB<sub>A</sub> Database.
11. Resync the archive volumes.

#### **3. REMOTE MIRROR AND COPY Phase between Primary DS8000 & Secondary DS8000:**

1. Withdraw Prior FlashCopy (FC) relation between DB<sub>B</sub> and DB<sub>C</sub>.
2. Alter Tablespace Begin Backup on DB<sub>A</sub>; Suspend the Database.
3. Freeze PPRC relations between DB<sub>A</sub> and DB<sub>B</sub>. (**OPTIONAL**) This step is not required for high availability point of view.



4. Unfreeze PPRC source volumes DB<sub>A</sub>. (**OPTIONAL**)
5. End backup steps for DB<sub>A</sub> Database, Repeat step 6 through 10 of phase 2.

In phase 3, pprcfreeze and pprcunfreeze commands are not mandatory. These commands will make sure no data is passing through DB<sub>A</sub> to DB<sub>B</sub> during the freeze. Again it is only option. For the customers who are looking for high availability, they can ignore pprc freeze option.

#### **4. FlashCopy Phase on Secondary DS8000:**

1. FlashCopy Data volumes DB<sub>B</sub> to DB<sub>C</sub>.
2. Unfreeze FlashCopy volumes on DB<sub>A</sub>.

#### **5. PPRC Phase between Primary DS8000 and Secondary DS8000:**

1. Re-establish PPRC path between DB<sub>A</sub> and DB<sub>B</sub>. (**OPTIONAL**)
2. Resume PPRC relation between DB<sub>A</sub> and DB<sub>B</sub>. (**OPTIONAL**)
3. Make sure PPRC status between DB<sub>A</sub> and DB<sub>B</sub> is 'Full Duplex'.

#### **6. FlashCopy Phase on Secondary DS8000:**

1. Perform an incremental FlashCopy for Archive Volumes between DB<sub>B</sub> and DB<sub>C</sub>.

#### **7. Second Instance Phase (target host):**

1. Run the following AIX commands config manager, convert all hdisks to vpaths using "cfallvpath" command, import the volume groups, vary on volume groups and mount filesystems scripts on the target host.
2. Create users and groups oracle and sap, dba and sapsys on target host if needed.
3. Make change to profile, user env, and permissions on target host for SAP<SID>adm and ora<SID>.
4. Make changes to /etc/services for SAP related entries. And other changes required by the SAP installation on AIX (refer SAP and AIX documentation).
5. Start oracle listener on target host.
6. Recover oracle database on target host
7. Startup mount; set autorecovery on; recover database using backup controlfile until cancel; alter database open resetlogs; on target host database.
8. Delete all print jobs and their lists on Target on target host database.
9. Update RFC on target host SAP
10. Start SAP on target host.
11. Logon to SAP on target host and run following SAP transaction "sick", to verify if the system shows-up any errors.

#### **8. New Backup Cycle Initialization Phase:**

In order to be prepared for a new backup cycle, the systems (DB<sub>B</sub>, DB<sub>C</sub> and DB<sub>D</sub>) must be set back to the start situation

In this SMBR solution, the following tasks were created using DS8000 DSCLI command sets:

Please review the dscli documentation for following dscli commands, lsprrc, mkpprc, mkpprcpath, mkflash, resyncflash, rmflash, unfreezeflash, freezepprc, unfreezepprc etc. The following SMBR steps will give the clear explanation on how to use these DSCLI commands.

## SMBR Implementation Steps in Detail

Each SMBR step is described as follows:

### Synchronize DB<sub>A</sub> to DB<sub>B</sub>

#### 1. Begin Phase:

Ensure that the pprc Paths exist (and LUN's are in Full Duplex on both DB<sub>A</sub> and target DB<sub>B</sub>) between PPRC source (DB<sub>A</sub>) and target (DB<sub>B</sub>) volumes; 'establish' if they do not already exist:

IF PPRC EXIST:

The lsprrc command displays the status information for each remote mirror and copy volume relationship in the list.

```
Dscli> lsprrc -dev IBM.2107-7505831 -remotedev IBM.2107-7510621 -l
1051:141F 100C-1012:1418-141E 101B-1022:1408-140F 1045-
104A:1436-143B 102B-102E:1426-1429 1037-1038:142E-142F 1088-
1089:1440-1441 102F:142A 1030:142B
Date/Time: April 26, 2005 3:28:24 PM CDT IBM DSCLI Version: 5.0.3.5
DS: IBM.2107-7505831
```

IF PPRC PATH DOES NOT EXIST:

mkpprcpath: command establishes or replaces a remote mirror and copy (formerly PPRC) path between source and target logical subsystems (LSSs) over a fibre channel connection.

```
Dscli> mkpprcpath -dev IBM.2107-7505831 -remotedev IBM.2107-
7510621 -consistgrp -srclss 10 -tgtlss 14 -remotewwnn
5005076303FFC0E4 I0201:I0201
Date/Time: April 26, 2005 3:20:26 PM CDT IBM DSCLI Version: 5.0.3.5
DS: IBM.2107-7505831
CMUC00149I mkpprcpath: Remote Mirror and Copy path 10:14
successfully established.
```

Ispprcpath: list of existing remote mirror and copy (formerly PPRC) path definitions.

```
dscli> Ispprcpath -dev IBM.2107-7505831 10
Date/Time: April 26, 2005 3:16:51 PM CDT IBM DSCLI Version: 5.0.3.5
DS: IBM.2107-7505831
Src Tgt State SS Port Attached Port
=====
10 14 Success FF14 I0201 I0201
```

mkpprc: command establishes a remote mirror and copy (formerly PPRC) relationship for a volume pair.

```
Dscli> mkpprc -dev IBM.2107-7505831 -remotedev IBM.2107-7510621 -
type mmir 1051:141F 100C-1012:1418-141E 101B-1022:1408-140F 1045-
104A:1436-143B 102B-102E:1426-1429 1037-1038:142E-142F 1088-
1089:1440-1441 102F:142A 1030:142B
```

## 2. FlashCopy Phase on Primary DS8000

Create a Safety FlashCopy of the Production Instance at PRIMARY-DS8000.

*Rmflash*: command removes a relationship between FlashCopy volume pairs.

```
Dscli> rmflash -dev IBM.2107-7505831 -quiet 1051:112B 100C-
1012:1124-112A 101B-1022:1114-111B 1045-104A:1142-1147 102B-
102E:1132-1135 1037-1038:113A-113B 1088-1089:1190-1191 102F:1136
1030:1137
```

Source database:

```
SQL> alter Tablespace <PSAP...> Begin Backup;
SQL> alter system suspend;
```

*Mkflash*: command initiates a point-in-time copy from source volumes to target volumes.

```
Dscli> mkflash -dev IBM.2107-7505831 -freeze -record -persist 1051:112B
100C-1012:1124-112A 101B-1022:1114-111B 1045-104A:1142-1147
102B-102E:1132-1135 1037-1038:113A-113B 1088-1089:1190-1191
102F:1136 1030:1137
```

*unfreezeflash*: command resets a FlashCopy consistency group that was previously established with the -freeze flag when the mkflash or inflash commands were issued



```
Dscli> unfreezeflash -dev IBM.2107-7505831 10
```

source database:

```
SQL> alter database Resume;  
SQL> alter Tablespace <PSAP...> End Backup;  
SQL> alter system archive log current;  
SQL> alter database backup controlfile to  
'/oracle/S01/oraarch/cntrlS01.dbf' REUSE;  
SQL> alter system archive log current;
```

*Resyncflash*: command (formerly called *incflash* for an incremental FlashCopy process) increments an existing FlashCopy pair that has been established with the *-record* and *-persist* flags.

```
Dscli> resyncflash -dev IBM.2107-7505831 1088:1189 – Archive luns only
```

### 3. PPRC Phase between Primary DS8000 & Secondary DS8000:

Create PPRC Between DB<sub>A</sub> & DB<sub>B</sub>, PRIMARY DS8000 and SECONDARY DS8000.

Remove a FlashCopy between DB<sub>B</sub> and DB<sub>C</sub> PRIMARY-DS8000.

*Rmflash*: command removes a relationship between FlashCopy volume pairs.

```
Dscli> rmflash -dev ${CLI_TARGET_SQ_DEV} -quiet  
${FCS_B_TO_C_VOLS}
```

Source database:

```
SQL> alter Tablespace <PSAP...> Begin Backup;  
SQL> alter system suspend;
```

*Freezepprc*: command creates a new remote mirror and copy consistency group. It places the source logical subsystem (LSS) in the long busy state so that no I/Os can be directed to it.

```
Dscli> freezepprc -dev ${CLI_SOURCE_SQ_DEV} -remotedev  
${CLI_TARGET_SQ_DEV} \  
${A_LSSID}:${B_LSSID}
```

*unfreezepprc*: command thaws an existing remote mirror and copy (formerly PPRC) consistency group. The command resets the queue full condition for the primary volume. All queued writes to the source volume are written.

```
Dscli> unfreezepprc -dev ${CLI_SOURCE_SQ_DEV} -remotedev  
${CLI_TARGET_SQ_DEV} \  
${A_LSSID}:${B_LSSID}
```

The above two DSCLI commands freezepprc and unfreezepprc are not required for high availability point of view. These two commands are not mandatory for split mirror process. This will command will make sure no data is transferred to secondary DS8000 server.

source database:

```
SQL> alter database Resume;  
SQL> alter Tablespace <PSAP...> End Backup;  
SQL> alter system archive log current;  
SQL> alter database backup controlfile to  
'/oracle/S01/oraarch/cntrlS01.dbf' REUSE;  
SQL> alter system archive log current;
```

#### 4. FlashCopy Phase on Secondary DS8000:

Create a FlashCopy of the between DB<sub>B</sub> and DB<sub>C</sub> at secondary DS8000:  
*Mkflash*: command initiates a point-in-time copy from source volumes to target volumes.

```
Dscli> mkflash -dev ${CLI_TARGET_SQ_DEV} -freeze -record -persist  
${FCS_B_TO_C_VOLS}
```

*unfreezeflash*: command resets a FlashCopy consistency group that was previously established with the -freeze flag when the mkflash or resyncflash commands were issued.

```
Dscli> unfreezeflash -dev ${CLI_TARGET_SQ_DEV} ${B_LSSID}
```

#### 5. PPRC Phase between Primary DS8000 & Secondary DS8000:

Create PPRC PATH Between DB<sub>A</sub> & DB<sub>B</sub>, primary DS8000 and secondary DS8000

*mkpprcpath*: command establishes or replaces a remote mirror and copy (formerly PPRC) path between source and target logical subsystems (LSSs) over a fibre channel connection.

```
Dscli> mkpprcpath -dev ${CLI_SOURCE_SQ_DEV} -remotedev  
${CLI_TARGET_SQ_DEV} \  
-consistgrp -src/ls ${A_LSSID} -tgt/ls ${B_LSSID} -remotewwnn  
${REMOTEWWNN} \  
${SOURCE_PORT_ID}:${TARGET_PORT_ID}
```

*resumepprc*: command resumes a remote mirror and copy (formerly PPRC) relationship for a volume pair.

```
Dscli> resumepprc -dev ${CLI_SOURCE_SQ_DEV} -remotedev  
${CLI_TARGET_SQ_DEV} \  
-type mmir ${PPRC_A_TO_B_VOLS}
```

Check if archive luns Between DB<sub>A</sub> & DB<sub>B</sub> are in Full Duplex State:

*Lspprc*: command displays a list of remote mirror and copy (formerly PPRC) volume relationships for a storage image, and status information for each remote mirror and copy volume relationship in the list.

```
Dscli> lspprc -dev ${CLI_SOURCE_SQ_DEV} -remotedev  
${CLI_TARGET_SQ_DEV} \  
${PPRC_A_TO_B_VOLS_ARCH}
```

The above (Step 5) commands are not required if *pprcfreeze* option is not used in Split Mirror Backup process.

## 6. FlashCopy Phase on Secondary DS8000:

*resyncflash*: command (formerly called *inflash* for an incremental FlashCopy process) increments an existing FlashCopy pair that has been established with the *-record* and *-persist* flags.

Resync archive luns Between DB<sub>A</sub> & DB<sub>C</sub>:

```
Dscli> resyncflash -dev ${CLI_TARGET_SQ_DEV} -record -persist \  
${FCS_B_TO_C_VOLS_ARCH}
```

## Appendix

### 9. Sample Scripts

Script for importing, varyoff volumes and mounting file systems.

```
-----
#!/usr/bin/ksh
#importvlg, varyonvg and mount filesystem.

TARGET_HOST=thunderbird
REMOTE_SHELL_CMD=/usr/bin/ssh
TGT_ORACLE_SID=S01
SQL_DIR=/scripts/pprc/SQL
TGT_FC_ADAPTER=fcs1
TGT_FC_ADAPTER_FSCSI=fscsi1

RC=0
x=1
#####
#The cfgmgr command configures devices and optionally installs device software
#into the system. The devices to be configured are controlled by the
#Configuration Rules object class, which is part of the Device Configuration
#database. Each configuration rule specifies three items:
#####
${REMOTE_SHELL_CMD} ${TARGET_HOST} "cfgmgr -l ${TGT_FC_ADAPTER}"

#####
#Get vpath's, SDD command cfallpath
#####
${REMOTE_SHELL_CMD} ${TARGET_HOST} "cfallvpath"

#####
#Check if the target mount point list were created
#####
if [[ -f ${SQL_DIR}/tgt_mountpoints_${TARGET_HOST}.lst ]]
then
    rm ${SQL_DIR}/tgt_mountpoints_${TARGET_HOST}.lst
fi
echo "\n"

#####
#Iterate through all the physical volumes, Import volume groups, create volume groups
#####
for fvpath in ` ${REMOTE_SHELL_CMD} ${TARGET_HOST} "lspv | grep None |tr -s ' '|cut -d ' ' -
f1|grep vpath"
do
    ##make sure the status of vpath is not 'concurrent or active'
    ${REMOTE_SHELL_CMD} ${TARGET_HOST} "lspv | grep None |tr -s ' '|cut -d ' ' -f1|grep
\"${fvpath}\" \"$>/dev/null
```

```

RC=$?
if [[ ${RC} = 0 ]]
then
    ###-----Import Volume Groups - Step-----##
    ${REMOTE_SHELL_CMD} ${TARGET_HOST} "importvg -y
    ${TGT_ORACLE_SID}sap0${x}vg ${fvpath}">/dev/null 2>&1
    RC=$?
    if [[ ${RC} = 0 ]]
    then
        ###-----Varyon - Step-----##
        ${REMOTE_SHELL_CMD} ${TARGET_HOST} "varyonvg
        ${TGT_ORACLE_SID}sap0${x}vg">/dev/null 2>&1
        let x=x+1
    else
        echo "Importvg ${fvpath} - Failed on host ${TARGET_HOST}"
    fi
fi
${REMOTE_SHELL_CMD} ${TARGET_HOST} "ls -l ${fvpath}|tr -s ' '|cut -d ' ' -f 5|grep ^[/]"
>> ${SQL_DIR}/tgt_mountpoints_${TARGET_HOST}.lst
done

###----- Mount - Step -----##
for mount_pt in `cat ${SQL_DIR}/tgt_mountpoints_${TARGET_HOST}.lst|sort`
do
    ${REMOTE_SHELL_CMD} ${TARGET_HOST} "mkdir -p ${mount_pt}" > /dev/null
    ${REMOTE_SHELL_CMD} ${TARGET_HOST} "mount ${mount_pt}" > /dev/null
done

```

The main Split Mirror Backup / Recovery script is shown below. In the lab, Secured Shell (SSH) is configured for communication between source and target hosts. Customers need to setup the secured shell on the hosts to use the following Split Mirror Backup scripts in their environment.

### smbr\_main.sh Script

```

#!/usr/bin/ksh

RC=0
SCRIPT_DIR=`pwd`
echo ${SCRIPT_DIR}

echo
"#####"
echo "`date | tr -s ' ' | cut -f4 -d ' '` Step - 1: SOURCE ENV VARIABLE FOR SHELL."
echo
"#####\n"
. ${SCRIPT_DIR}/env_source.sh
RC=$?
if [[ ${RC} -ne 0 ]]
then
    echo "Error during ${SCRIPT_DIR}/env_source.sh execution."
    exit 2
fi

```



## Split Mirror Backup / Recovery Solution with the IBM TotalStorage DS8000 Series

```
echo
#####
echo ""date | tr -s ' ' | cut -f4 -d ' '" Step - 2: Check for Current user: root, dscli, ssh"
echo
#####\n"
time . ${EXE_DIR}/test_env_variable.sh 2>&1 | tee ${LOG_DIR}/test_env_variable.log
egrep 'ERROR|Error|error' ${LOG_DIR}/test_env_variable.log >/dev/null
RC=$?
if [[ ${RC} = 0 ]]
then
    echo "Step-2: Check for Current user: root, dscli, ssh - Failed"
    exit 2
fi

echo
#####
echo ""date | tr -s ' ' | cut -f4 -d ' '" Step - 3: Make sure pprc status 'Full Duplex' between A and B."
echo
#####\n"
time . ${EXE_DIR}/lspprc_A_to_B_scripts.sh 2>&1 | tee ${LOG_DIR}/lspprc_A_to_B_scripts.log
egrep 'ERROR|Error|error' ${LOG_DIR}/lspprc_A_to_B_scripts.log >/dev/null
RC=$?
if [[ ${RC} = 0 ]]
then
    echo "Step-3 pprc status is not 'Full Duplex' between A and B: Error."
    exit 2
fi

echo
#####
echo ""date | tr -s ' ' | cut -f4 -d ' '" Step - 4: Check for database status: OPEN."
echo
#####\n"
chmod -R 777 ${SQL_DIR}
rm ${SQL_DIR}/source_db_status.lst >/dev/null
su - ${SRC_DB_OWNER_ID} -c 'sqlplus -s "/as sysdba"<<ENF>/dev/null
    set heading off
    set feedback off
        alter system resume;
    pool ${SQL_DIR}/source_db_status.lst
    select status from v$instance;
    pool off
ENF
grep "OPEN" ${SQL_DIR}/source_db_status.lst >/dev/null
RC=$?
if [[ ${RC} != 0 ]]
then
    echo "Step-4 Source database must have OPEN status, Error."
    exit 2
fi

echo
#####
echo ""date | tr -s ' ' | cut -f4 -d ' '" Step - 5: STOP DATABASE and SAP on TARGET."
echo
#####\n"
```



## Split Mirror Backup / Recovery Solution with the IBM TotalStorage DS8000 Series

```
time . ${EXE_DIR}/tgt_stop_sap.sh 2>&1 | tee ${LOG_DIR}/tgt_stop_sap.log
egrep 'ERROR|Error|error' ${LOG_DIR}/tgt_stop_sap.log >/dev/null
RC=$?
if [[ ${RC} = 0 ]]
then
    echo "Step-5: check the required env variables, and review logfile:
${LOG_DIR}/tgt_stop_sap.log."
    exit 2
fi

echo
"#####"
echo ""date | tr -s ' ' | cut -f4 -d ' '" Step - 6: FCS_A_to_D flash copy."
echo
"#####\n"
time . ${EXE_DIR}/FCS_A_to_D_script.sh 2>&1 | tee ${LOG_DIR}/FCS_A_to_D_script.log
egrep 'ERROR|Error|error' ${LOG_DIR}/FCS_A_to_D_script.log >/dev/null
RC=$?
if [[ ${RC} = 0 ]]
then
    echo "Step-6: error Executing FCS_A_to_D_script.sh, RC=${RC}"
    exit 2
fi

echo
"#####"
echo ""date | tr -s ' ' | cut -f4 -d ' '" Step - 7: FCS_A_to_B PPRC."
echo
"#####\n"
time . ${EXE_DIR}/PPRC_A_to_B_script.sh 2>&1 | tee ${LOG_DIR}/PPRC_A_to_B_script.log
egrep 'ERROR|Error|error' ${LOG_DIR}/PPRC_A_to_B_script.log>/dev/null
RC=$?
if [[ ${RC} = 0 ]]
then
    echo "Step-7: error Executing PPRC_A_to_B_script.sh, RC=${RC}."
    exit 2
fi

echo
"#####"
echo ""date | tr -s ' ' | cut -f4 -d ' '" Step - 8: FCS_B_to_C flash copy."
echo
"#####\n"
time . ${EXE_DIR}/FCS_B_to_C_script.sh 2>&1 | tee ${LOG_DIR}/FCS_B_to_C_script.log
egrep 'ERROR|Error|error' ${LOG_DIR}/FCS_B_to_C_script.log>/dev/null
RC=$?
if [[ ${RC} = 0 ]]
then
    echo "Step-8: error Executing FCS_B_to_C_script.sh, RC=${RC}."
    exit 2
fi

echo
"#####"
echo ""date | tr -s ' ' | cut -f4 -d ' '" Step - 9: START DATABASE and SAP on TARGET."
echo
"#####\n"
```



## Split Mirror Backup / Recovery Solution with the IBM TotalStorage DS8000 Series

```
time . ${EXE_DIR}/tgt_start_sap.sh 2>&1 | tee ${LOG_DIR}/tgt_start_sap.log
RC=$?
if [[ ${RC} != 0 ]]
then
    echo "Step-9: Error Executing ${EXE_DIR}/tgt_start_sap.sh."
    exit 2
fi

echo
"#####"
echo "`date | tr -s ' ' | cut -f4 -d '`" SMBR Steps completed."
echo
"#####\n"
```

Customer needs to provide the data to the Input Config File which is shown below in blue color.

## 10. Input Config Files

### env\_source.sh file

```
#!/usr/bin/ksh
#####
#
# Envinomental variables for SMBR scripts
#####

SCRIPT_DIR=/manju/scripts/pprc      #Please don't user `pwd` - other
scripts will not work - thanks
IGNORE_PPRC_FREEZE=Y #Valid input Y and N, Y=Yes N=NO
REMOTE_SHELL_CMD=/usr/bin/ssh
TARGET_HOST=thunderbird
SOURCE_HOST=lamborgini
ORACLE_SID=S01                      ## Always Source oracle SID
TGT_ORACLE_SID=${ORACLE_SID}        ## For pprc with no SID Change
ORACLE_HOME=/oracle/${ORACLE_SID}/920_64
SOURCE_SAP_SCHEMA=SAPS01

SAP_SYSID=S01
TGT_SAP_SYSID=${SAP_SYSID}
SRC_DB_OWNER_ID=ora`echo ${ORACLE_SID} | tr 'A-Z' 'a-z'`
TGT_DB_OWNER_ID=ora`echo ${TGT_ORACLE_SID} | tr 'A-Z' 'a-z'`
SRC_SAP_OWNER_ID=`echo ${SAP_SYSID} | tr 'A-Z' 'a-z'`adm
TGT_SAP_OWNER_ID=`echo ${TGT_SAP_SYSID} | tr 'A-Z' 'a-z'`adm

TGT_ORA_USR_HOME=/oracle/${TGT_ORACLE_SID}
TGT_SAP_USR_HOME=/home/`echo ${TGT_SAP_SYSID} | tr 'A-Z' 'a-z'`adm
SRC_ORA_USR_HOME=/oracle/${ORACLE_SID}
SRC_SAP_USR_HOME=/home/${SRC_SAP_OWNER_ID}
TGT_SAP_PROFILE_DIR=/sapmnt/${TGT_SAP_SYSID}/profile
SRC_SAP_PROFILE_DIR=/sapmnt/${SAP_SYSID}/profile

TGT_FC_ADAPTER=fcs1
TGT_FC_ADAPTER_FSCSI=fscsil

#####
##CLI_SOURCE_SQ_IP=oslsq04 #SQ04 STORAGE
#CLI_TARGET_SQ_IP=oslsq05 #SQ05 STORAGE
# Storage console configuration information
#####

CLI_SOURCE_SQ_IP=9.43.225.101 #SQ04 STORAGE
CLI_TARGET_SQ_IP=9.43.225.113 #SQ05 STORAGE

CLI_SOURCE_SQ_DEV=IBM.2107-7505831 #SQ04
CLI_TARGET_SQ_DEV=IBM.2107-7510621 #SQ05

CLI_SRC_USER_ID=admin
CLI_SRC_PASSWD=admin
CLI_TGT_USER_ID=admin
```



## Split Mirror Backup / Recovery Solution with the IBM TotalStorage DS8000 Series

```
CLI_TGT_PASSWD=sanj0se

SOURCE_PORT_ID=I0201
TARGET_PORT_ID=I0201

#SOURCE_PORT_ID=I0330
#TARGET_PORT_ID=I0202
REMOTEWNN=5005076303FFC0E4

#####
# Check to for Source hmc available
#####
DSCLI_SRC_CMD="dscli -hmc1 ${CLI_SOURCE_SQ_IP} -hmc2 {CLI_SOURCE_SQ_IP}
-user ${CLI_SRC_USER_ID} -passwd ${CLI_SRC_PASSWD}"

#####
# Check to for Target hmc available
#####

DSCLI_TGT_CMD="dscli -hmc1 ${CLI_TARGET_SQ_IP} -hmc2
${CLI_TARGET_SQ_IP} -user ${CLI_TGT_USER_ID} -passwd
${CLI_TGT_PASSWD}"

LIBPATH=$ORACLE_HOME/lib:/sapmnt/${SAP_SYSID}/exe

#####
# Check to for validity of DSCLI
#####

DSCLI=/opt/ibm/dscli
if [[ ! -f $DSCLI/dscli ]]
then
    echo "$DSCLI directory is invalid"
    exit 3
fi

PATH=$ORACLE_HOME/bin:$DSCLI:$PATH

EXE_DIR=${SCRIPT_DIR}/exe

#####
# Check to for log directory availability
#####

LOG_DIR=${SCRIPT_DIR}/log
if [[ ! -d $LOG_DIR ]]
then
    mkdir -p $LOG_DIR
    chmod -R 775 $LOG_DIR
fi

#####
# Check to for LUN's table location directory
#####

LUN_PAIR=${SCRIPT_DIR}/lun_pair
```



## Split Mirror Backup / Recovery Solution with the IBM TotalStorage DS8000 Series

```
if [[ ! -d ${LUN_PAIR}/lun_pair ]]
then
    mkdir -p ${LUN_PAIR}
    chmod -R 775 ${LUN_PAIR}
fi

#####
# Check to for Table availability
#####
PPRC_VOLS=${LUN_PAIR}/pprc_vols.dat
if [[ ! -f ${PPRC_VOLS} ]]
then
    echo "${PPRC_VOLS} file does not exist"
    exit 5
fi

#####
# Check to for Dynamic SQL directory availability
#####
SQL_DIR="${SCRIPT_DIR}/SQL"
if [[ ! -d ${SQL_DIR} ]]
then
    mkdir -p ${SQL_DIR}
    chmod -R 777 ${SQL_DIR}
fi

#####
# Check to for Backup control file location directory and file availability
#####
if [[ ! -d ${BACKUP_CONTROLFILE_NAME} ]]
then

BACKUP_CONTROLFILE_NAME="/oracle/${ORACLE_SID}/oraarch/cntrl${ORACLE_SI
D}.dbf"
    if [[ -f ${BACKUP_CONTROLFILE_NAME} ]]
    then
        rm ${BACKUP_CONTROLFILE_NAME}
    fi
fi

#####
# Source for A, B, C, and D vols in to variable's to be used with DSCLI commands
#####

. ${EXE_DIR}/pprc_vols_pair_data.sh
RC=$?
if [[ ${RC} -ne 0 ]]
then
    echo "Error running ${EXE_DIR}/pprc_vols_pair_data.sh"
    exit33
fi

#####
# LUN's table to be used with DSCLI command
```



#####

/lun\_pair/pprc\_vols.dat

---

```
## Example of 1 to 1 luns:
##### lunA:lunB:lunC:lunD
## Example of grouped luns
##### lunA1-lunA4:lunB1-lunB4:lunC2-lunC5:lunD1-
lunD4
## Example of grouped ARCHIVE luns
##### lunA6-lunA7:lunB6-lunB7:lunC8-lunC9:lunD6-
lunD7:ARCH
1051:141F:111F:112B
100C-1012:1418-141E:1118-111E:1124-112A
101B-1022:1408-140F:1108-110F:1114-111B
1045-104A:1436-143B:1136-113B:1142-1147
102B-102E:1426-1429:1126-1129:1132-1135
1037-1038:142E-142F:112E-112F:113A-113B
1088-1089:1440-1441:1150-1151:1190-1191
102F:142A:112A:1136:ARCH
1030:142B:112B:1137:ARCH
```

## 11. Hardware used

The following hardware is used for Split Mirror Backup / Recovery solution in the lab.

<b>Server System</b>	<b>IBM pSeries 690</b> 24 CPUs, 32 GB Memory		
Host	Used as	CPUs	Memory
Lamborghini	Production System	6	6 GB
Thunderbird	Backup System	4	5 GB
<b>Storage System</b>	<b>IBM DS8000 1 (IBM.2107-7505831)</b>		
Disk	Characteristics	Size	Number
Physical Drive	RAID 5	2 GB	2 x 8
Physical Drive	RAID 5	5 GB	2 x 8
Physical Drive	RAID 5	10 GB	2 x 12
Physical Drive	RAID 5	20 GB	2 x 4
Physical Drive	RAID 5	40 GB	2 x 4
<b>Storage System</b>	<b>IBM DS8000 2 (IBM.2107-7510621)</b>		
Disk	Characteristics	Size	Number
Physical Drive	RAID 5	2 GB	2 x 8
Physical Drive	RAID 5	5 GB	2 x 8
Physical Drive	RAID 5	10 GB	2 x 12
Physical Drive	RAID 5	20 GB	2 x 4
Physical Drive	RAID 5	40 GB	2 x 4
<b>Connection</b>	<b>Switched Fibre Fabric (1 Brocade 16 Port Switch)</b>		
Switch to	Characteristics	Number	
Server-Node	Emulex LP9802	1	

## 12. Software used

The following software is used for the Split Mirror Backup / Recovery solution in the lab.

Type	Software	Version
Storage	IBM DS8000 Microcode level	6.0.0.319
	IBM DSCLI	5.0.3.61
Operating System	AIX 5L	5.2.0.0 -04
Database System	Oracle 9i	9.2.0.6
SAP	S01 – Production Central and DB Instance	4.7
	B01 – Backup Central and DB Instance	4.7
Miscellaneous	OpenSSH	3.8.1p1
	OpenSSL	0.9.7d

## 13. Logs

The Split Mirror Backup & Recovery process log output is directed to the following three log files. FlashCopy phase log, PPRC phase log and FlashCopy phase at Target DS8000.

FCS\_A\_to\_D\_script.log  
PPRC\_A\_to\_B\_script.log  
FCS\_B\_to\_C\_script.log

Basically the log output is divided into three files to make it more easy for customer to identify the errors.

---

### /log/FCS\_A\_to\_D\_script.log

---

```
09:01:54 ##### REMOVE FLASH FCS_A_TO_D_VOLS DCSLI.  
Date/Time: April 20, 2005 9:01:58 AM CDT IBM DSCLI Version: 5.0.3.13  
DS: IBM.2107-7505831  
CMUC00140I rmflash: FlashCopy pair 1051:112B successfully removed.  
CMUC00140I rmflash: FlashCopy pair 100C:1124 successfully removed.  
CMUC00140I rmflash: FlashCopy pair 100D:1125 successfully removed.  
CMUC00140I rmflash: FlashCopy pair 100E:1126 successfully removed.  
CMUC00140I rmflash: FlashCopy pair 100F:1127 successfully removed.  
CMUC00140I rmflash: FlashCopy pair 1010:1128 successfully removed.  
CMUC00140I rmflash: FlashCopy pair 1011:1129 successfully removed.  
CMUC00140I rmflash: FlashCopy pair 1012:112A successfully removed.  
CMUC00140I rmflash: FlashCopy pair 101B:1114 successfully removed.  
CMUC00140I rmflash: FlashCopy pair 101C:1115 successfully removed.  
CMUC00140I rmflash: FlashCopy pair 101D:1116 successfully removed.  
CMUC00140I rmflash: FlashCopy pair 101E:1117 successfully removed.  
CMUC00140I rmflash: FlashCopy pair 101F:1118 successfully removed.  
CMUC00140I rmflash: FlashCopy pair 1020:1119 successfully removed.  
CMUC00140I rmflash: FlashCopy pair 1021:111A successfully removed.  
CMUC00140I rmflash: FlashCopy pair 1022:111B successfully removed.  
CMUC00140I rmflash: FlashCopy pair 1045:1142 successfully removed.  
CMUC00140I rmflash: FlashCopy pair 1046:1143 successfully removed.  
CMUC00140I rmflash: FlashCopy pair 1047:1144 successfully removed.  
CMUC00140I rmflash: FlashCopy pair 1048:1145 successfully removed.  
CMUC00140I rmflash: FlashCopy pair 1049:1146 successfully removed.  
CMUC00140I rmflash: FlashCopy pair 104A:1147 successfully removed.  
CMUC00140I rmflash: FlashCopy pair 102B:1132 successfully removed.  
CMUC00140I rmflash: FlashCopy pair 102C:1133 successfully removed.  
CMUC00140I rmflash: FlashCopy pair 102D:1134 successfully removed.  
CMUC00140I rmflash: FlashCopy pair 102E:1135 successfully removed.  
CMUC00140I rmflash: FlashCopy pair 1037:113A successfully removed.  
CMUC00140I rmflash: FlashCopy pair 1038:113B successfully removed.  
CMUC00140I rmflash: FlashCopy pair 1088:1190 successfully removed.  
CMUC00140I rmflash: FlashCopy pair 1089:1191 successfully removed.  
CMUC00140I rmflash: FlashCopy pair 102F:1136 successfully removed.  
CMUC00140I rmflash: FlashCopy pair 1030:1137 successfully removed.  
  
real 0m16.54s  
user 0m5.49s  
sys 0m0.57s  
09:02:10 ##### BEGIN BACKUP DATABASE A.
```



## Split Mirror Backup / Recovery Solution with the IBM TotalStorage DS8000 Series

```
09:02:10 ##### TABLESPACE - BEGIN BACKUP - IN BACK GROUND Started.
          09:02:13 ##### SYSTEM - Tablespace is in backup mode - START.
          09:02:13 ##### PSAPSSQJI - Tablespace is in backup mode -
START.
          09:02:13 ##### PSAPSSQJD - Tablespace is in backup mode -
START.
          09:02:13 ##### PSAPS01USR - Tablespace is in backup mode -
START.
          09:02:13 ##### PSAPS01620 - Tablespace is in backup mode -
START.
          09:02:13 ##### PSAPS01 - Tablespace is in backup mode -
START.
          09:02:13 ##### PSAPROLL - Tablespace is in backup mode -
START.
          09:02:14 ##### PSAPS01USR - Tablespace is in backup mode
completed - END.
          09:02:21 ##### PSAPS01 - Tablespace is in backup mode
completed - END.
          09:02:21 ##### PSAPS01620 - Tablespace is in backup mode
completed - END.
          09:02:24 ##### SYSTEM - Tablespace is in backup mode
completed - END.
          09:02:29 ##### PSAPROLL - Tablespace is in backup mode
completed - END.
          09:04:31 ##### PSAPSSQJD - Tablespace is in backup mode
completed - END.
          09:05:06 ##### PSAPSSQJI - Tablespace is in backup mode
completed - END.
09:05:11 ##### Source database is in SUSPENDED state.
09:05:11 ##### TABLESPACE - BEGIN BACKUP - IN BACK GROUND Completed.
```

```
real 3m0.49s
user 0m0.36s
sys 0m2.04s
```

```
09:05:11 ##### MAKE FLASH FCS_A_TO_D_VOLS.
Date/Time: April 20, 2005 9:05:15 AM CDT IBM DSCLI Version: 5.0.3.13
DS: IBM.2107-7505831
```

```
CMUC00137I mkflash: FlashCopy pair 1051:112B successfully created.
CMUC00137I mkflash: FlashCopy pair 100C:1124 successfully created.
CMUC00137I mkflash: FlashCopy pair 100D:1125 successfully created.
CMUC00137I mkflash: FlashCopy pair 100E:1126 successfully created.
CMUC00137I mkflash: FlashCopy pair 100F:1127 successfully created.
CMUC00137I mkflash: FlashCopy pair 1010:1128 successfully created.
CMUC00137I mkflash: FlashCopy pair 1011:1129 successfully created.
CMUC00137I mkflash: FlashCopy pair 1012:112A successfully created.
CMUC00137I mkflash: FlashCopy pair 101B:1114 successfully created.
CMUC00137I mkflash: FlashCopy pair 101C:1115 successfully created.
CMUC00137I mkflash: FlashCopy pair 101D:1116 successfully created.
CMUC00137I mkflash: FlashCopy pair 101E:1117 successfully created.
CMUC00137I mkflash: FlashCopy pair 101F:1118 successfully created.
CMUC00137I mkflash: FlashCopy pair 1020:1119 successfully created.
CMUC00137I mkflash: FlashCopy pair 1021:111A successfully created.
CMUC00137I mkflash: FlashCopy pair 1022:111B successfully created.
CMUC00137I mkflash: FlashCopy pair 1045:1142 successfully created.
CMUC00137I mkflash: FlashCopy pair 1046:1143 successfully created.
CMUC00137I mkflash: FlashCopy pair 1047:1144 successfully created.
```



## Split Mirror Backup / Recovery Solution with the IBM TotalStorage DS8000 Series

```
CMUC00137I mkflash: FlashCopy pair 1048:1145 successfully created.
CMUC00137I mkflash: FlashCopy pair 1049:1146 successfully created.
CMUC00137I mkflash: FlashCopy pair 104A:1147 successfully created.
CMUC00137I mkflash: FlashCopy pair 102B:1132 successfully created.
CMUC00137I mkflash: FlashCopy pair 102C:1133 successfully created.
CMUC00137I mkflash: FlashCopy pair 102D:1134 successfully created.
CMUC00137I mkflash: FlashCopy pair 102E:1135 successfully created.
CMUC00137I mkflash: FlashCopy pair 1037:113A successfully created.
CMUC00137I mkflash: FlashCopy pair 1038:113B successfully created.
CMUC00137I mkflash: FlashCopy pair 1088:1190 successfully created.
CMUC00137I mkflash: FlashCopy pair 1089:1191 successfully created.
CMUC00137I mkflash: FlashCopy pair 102F:1136 successfully created.
CMUC00137I mkflash: FlashCopy pair 1030:1137 successfully created.

real  0m15.72s
user  0m5.35s
sys   0m0.33s
      09:05:26 ##### UNFREEZE FLASH A_to_D.
Date/Time: April 20, 2005 9:05:29 AM CDT IBM DSCLI Version: 5.0.3.13
DS: IBM.2107-7505831
CMUC00172I unfreezeflash: FlashCopy consistency group for logical
subsystem 10: successfully reset.

real  0m13.32s
user  0m4.48s
sys   0m0.23s
      09:05:40 ##### END BACKUP DATABASE A.
      09:05:40 ##### Source database - resumed step Completed.
      09:05:40 ##### DATABASE - Alter system resume - Completed.
      09:05:40 ##### TABLESPACE - END BACKUP - IN BACK GROUND - START.
      09:05:40 ##### SYSTEM - Tablespace not in backup mode -
START.
      09:05:40 ##### PSAPSSQJI - Tablespace not in backup mode -
START.
      09:05:40 ##### PSAPSSQJD - Tablespace not in backup mode -
START.
      09:05:41 ##### PSAPS01USR - Tablespace not in backup mode -
START.
      09:05:41 ##### PSAPS01620 - Tablespace not in backup mode -
START.
      09:05:41 ##### PSAPS01 - Tablespace not in backup mode -
START.
      09:05:41 ##### PSAPROLL - Tablespace not in backup mode -
START.
      09:05:44 ##### PSAPS01USR - Tablespace not in backup mode -
completed - END.
      09:05:47 ##### SYSTEM - Tablespace not in backup mode -
completed - END.
      09:05:47 ##### PSAPROLL - Tablespace not in backup mode -
completed - END.
      09:05:47 ##### PSAPSSQJI - Tablespace not in backup mode -
completed - END.
      09:05:47 ##### PSAPSSQJD - Tablespace not in backup mode -
completed - END.
      09:05:49 ##### PSAPS01620 - Tablespace not in backup mode -
completed - END.
```



## Split Mirror Backup / Recovery Solution with the IBM TotalStorage DS8000 Series

```
09:05:52 ##### PSAPS01 - Tablespace not in backup mode -
completed - END.
09:06:00 ##### Source: Backup Controlfile to
'/oracle/S01/oraarch/cntrlS01.dbf' - Completed.
09:06:00 ##### System altered: Archive log current - Completed.
09:06:00 ##### TABLESPACE - END BACKUP - IN BACK GROUND Completed -
END.

real 0m20.70s
user 0m0.50s
sys 0m1.92s
09:06:00 ##### MAKE FLASH FCS_A_TO_D_VOLS_ARCH.
Date/Time: April 20, 2005 9:06:03 AM CDT IBM DSCLI Version: 5.0.3.13
DS: IBM.2107-7505831
CMUC00168I resyncflash: FlashCopy volume pair 102F:1136 successfully
resynched.
CMUC00168I resyncflash: FlashCopy volume pair 1030:1137 successfully
resynched.

real 0m14.34s
user 0m4.76s
sys 0m0.25s
09:06:15 ##### FCS_A_to_D COMPLETED.
```

---

### /log/PPRC\_A\_to\_B\_script.log

---

```
09:06:15 ##### REMOVE FLASH - FCS_B_to_C.
Date/Time: April 20, 2005 9:06:18 AM CDT IBM DSCLI Version: 5.0.3.13
DS: IBM.2107-7510621
CMUC00140I rmflash: FlashCopy pair 141F:111F successfully removed.
CMUC00140I rmflash: FlashCopy pair 1418:1118 successfully removed.
CMUC00140I rmflash: FlashCopy pair 1419:1119 successfully removed.
CMUC00140I rmflash: FlashCopy pair 141A:111A successfully removed.
CMUC00140I rmflash: FlashCopy pair 141B:111B successfully removed.
CMUC00140I rmflash: FlashCopy pair 141C:111C successfully removed.
CMUC00140I rmflash: FlashCopy pair 141D:111D successfully removed.
CMUC00140I rmflash: FlashCopy pair 141E:111E successfully removed.
CMUC00140I rmflash: FlashCopy pair 1408:1108 successfully removed.
CMUC00140I rmflash: FlashCopy pair 1409:1109 successfully removed.
CMUC00140I rmflash: FlashCopy pair 140A:110A successfully removed.
CMUC00140I rmflash: FlashCopy pair 140B:110B successfully removed.
CMUC00140I rmflash: FlashCopy pair 140C:110C successfully removed.
CMUC00140I rmflash: FlashCopy pair 140D:110D successfully removed.
CMUC00140I rmflash: FlashCopy pair 140E:110E successfully removed.
CMUC00140I rmflash: FlashCopy pair 140F:110F successfully removed.
CMUC00140I rmflash: FlashCopy pair 1436:1136 successfully removed.
CMUC00140I rmflash: FlashCopy pair 1437:1137 successfully removed.
CMUC00140I rmflash: FlashCopy pair 1438:1138 successfully removed.
CMUC00140I rmflash: FlashCopy pair 1439:1139 successfully removed.
CMUC00140I rmflash: FlashCopy pair 143A:113A successfully removed.
CMUC00140I rmflash: FlashCopy pair 143B:113B successfully removed.
CMUC00140I rmflash: FlashCopy pair 1426:1126 successfully removed.
CMUC00140I rmflash: FlashCopy pair 1427:1127 successfully removed.
CMUC00140I rmflash: FlashCopy pair 1428:1128 successfully removed.
CMUC00140I rmflash: FlashCopy pair 1429:1129 successfully removed.
```



## Split Mirror Backup / Recovery Solution with the IBM TotalStorage DS8000 Series

```
CMUC00140I rmflash: FlashCopy pair 142E:112E successfully removed.
CMUC00140I rmflash: FlashCopy pair 142F:112F successfully removed.
CMUC00140I rmflash: FlashCopy pair 1440:1150 successfully removed.
CMUC00140I rmflash: FlashCopy pair 1441:1151 successfully removed.
CMUC00140I rmflash: FlashCopy pair 142A:112A successfully removed.
CMUC00140I rmflash: FlashCopy pair 142B:112B successfully removed.

real  0m13.62s
user  0m5.03s
sys   0m0.34s
      09:06:28 ##### BEGIN BACKUP - DATABASE A.
09:06:28 ##### TABLESPACE - BEGIN BACKUP - IN BACK GROUND Started.
      09:06:29 ##### SYSTEM - Tablespace is in backup mode - START.
      09:06:29 ##### PSAPSSQJI - Tablespace is in backup mode -
START.
      09:06:29 ##### PSAPS01USR - Tablespace is in backup mode -
START.
      09:06:29 ##### PSAPSSQJD - Tablespace is in backup mode -
START.
      09:06:29 ##### PSAPS01620 - Tablespace is in backup mode -
START.
      09:06:29 ##### PSAPROLL - Tablespace is in backup mode -
START.
      09:06:29 ##### PSAPS01 - Tablespace is in backup mode -
START.
      09:06:39 ##### PSAPS01USR - Tablespace is in backup mode
completed - END.
      09:06:42 ##### PSAPS01620 - Tablespace is in backup mode
completed - END.
      09:06:50 ##### PSAPS01 - Tablespace is in backup mode
completed - END.
      09:06:56 ##### SYSTEM - Tablespace is in backup mode
completed - END.
      09:06:56 ##### PSAPROLL - Tablespace is in backup mode
completed - END.
      09:08:28 ##### PSAPSSQJD - Tablespace is in backup mode
completed - END.
      09:08:32 ##### PSAPSSQJI - Tablespace is in backup mode
completed - END.
09:08:39 ##### Source database is in SUSPENDED state.
09:08:39 ##### TABLESPACE - BEGIN BACKUP - IN BACK GROUND Completed.

real  2m10.85s
user  0m0.43s
sys   0m1.72s
      09:08:39 ##### FREEZE PPRC - PPRC_A_to_B.
Date/Time: April 20, 2005 9:08:42 AM CDT IBM DSCLI Version: 5.0.3.13
DS: IBM.2107-7505831
CMUC00161W freezepprc: Remote Mirror and Copy consistency group 10:14
successfully created.

real  0m13.40s
user  0m4.71s
sys   0m0.24s
      09:08:53 ##### UNFREEZE PPRC - PPRC_A_to_B.
```



## Split Mirror Backup / Recovery Solution with the IBM TotalStorage DS8000 Series

Date/Time: April 20, 2005 9:08:55 AM CDT IBM DSCLI Version: 5.0.3.13  
DS: IBM.2107-7505831  
CMUC00198I unfreezeprc: Remote Mirror and Copy pair 10:14 successfully  
thawed.

```
real 0m13.05s
user 0m4.59s
sys 0m0.28s
09:09:06 ##### END BACKUP - DATABASE A.
09:09:06 ##### Source database - resumed step Completed.
09:09:07 ##### DATABASE - Alter system resume - Completed.
09:09:07 ##### TABLESPACE - END BACKUP - IN BACK GROUND - START.
09:09:07 ##### SYSTEM - Tablespace not in backup mode -
START.
09:09:07 ##### PSAPSSQJI - Tablespace not in backup mode -
START.
09:09:07 ##### PSAPSSQJD - Tablespace not in backup mode -
START.
09:09:07 ##### PSAPS01USR - Tablespace not in backup mode -
START.
09:09:07 ##### PSAPS01620 - Tablespace not in backup mode -
START.
09:09:07 ##### PSAPS01 - Tablespace not in backup mode -
START.
09:09:07 ##### PSAPROLL - Tablespace not in backup mode -
START.
09:09:07 ##### PSAPROLL - Tablespace not in backup mode -
completed - END.
09:09:07 ##### SYSTEM - Tablespace not in backup mode -
completed - END.
09:09:07 ##### PSAPSSQJD - Tablespace not in backup mode -
completed - END.
09:09:15 ##### PSAPSSQJI - Tablespace not in backup mode -
completed - END.
09:09:15 ##### PSAPS01USR - Tablespace not in backup mode -
completed - END.
09:09:16 ##### PSAPS01620 - Tablespace not in backup mode -
completed - END.
09:09:18 ##### PSAPS01 - Tablespace not in backup mode -
completed - END.
09:09:57 ##### Source: Backup Controlfile to
'/oracle/S01/oraarch/cntrlS01.dbf' - Completed.
09:09:57 ##### System altered: Archive log current - Completed.
09:09:57 ##### TABLESPACE - END BACKUP - IN BACK GROUND Completed -
END.

real 0m51.03s
user 0m0.44s
sys 0m2.10s
09:09:57 ##### PPRC_A_to_B COMPLETED.
```

---

**/log/FCS\_B\_to\_C\_script.log**

---

09:09:57 ##### MAKE FLASH - FCS\_B\_TO\_C\_VOLS.



## Split Mirror Backup / Recovery Solution with the IBM TotalStorage DS8000 Series

Date/Time: April 20, 2005 9:10:00 AM CDT IBM DSCLI Version: 5.0.3.13  
DS: IBM.2107-7510621

```
CMUC00137I mkflash: FlashCopy pair 141F:111F successfully created.
CMUC00137I mkflash: FlashCopy pair 1418:1118 successfully created.
CMUC00137I mkflash: FlashCopy pair 1419:1119 successfully created.
CMUC00137I mkflash: FlashCopy pair 141A:111A successfully created.
CMUC00137I mkflash: FlashCopy pair 141B:111B successfully created.
CMUC00137I mkflash: FlashCopy pair 141C:111C successfully created.
CMUC00137I mkflash: FlashCopy pair 141D:111D successfully created.
CMUC00137I mkflash: FlashCopy pair 141E:111E successfully created.
CMUC00137I mkflash: FlashCopy pair 1408:1108 successfully created.
CMUC00137I mkflash: FlashCopy pair 1409:1109 successfully created.
CMUC00137I mkflash: FlashCopy pair 140A:110A successfully created.
CMUC00137I mkflash: FlashCopy pair 140B:110B successfully created.
CMUC00137I mkflash: FlashCopy pair 140C:110C successfully created.
CMUC00137I mkflash: FlashCopy pair 140D:110D successfully created.
CMUC00137I mkflash: FlashCopy pair 140E:110E successfully created.
CMUC00137I mkflash: FlashCopy pair 140F:110F successfully created.
CMUC00137I mkflash: FlashCopy pair 1436:1136 successfully created.
CMUC00137I mkflash: FlashCopy pair 1437:1137 successfully created.
CMUC00137I mkflash: FlashCopy pair 1438:1138 successfully created.
CMUC00137I mkflash: FlashCopy pair 1439:1139 successfully created.
CMUC00137I mkflash: FlashCopy pair 143A:113A successfully created.
CMUC00137I mkflash: FlashCopy pair 143B:113B successfully created.
CMUC00137I mkflash: FlashCopy pair 1426:1126 successfully created.
CMUC00137I mkflash: FlashCopy pair 1427:1127 successfully created.
CMUC00137I mkflash: FlashCopy pair 1428:1128 successfully created.
CMUC00137I mkflash: FlashCopy pair 1429:1129 successfully created.
CMUC00137I mkflash: FlashCopy pair 142E:112E successfully created.
CMUC00137I mkflash: FlashCopy pair 142F:112F successfully created.
CMUC00137I mkflash: FlashCopy pair 1440:1150 successfully created.
CMUC00137I mkflash: FlashCopy pair 1441:1151 successfully created.
CMUC00137I mkflash: FlashCopy pair 142A:112A successfully created.
CMUC00137I mkflash: FlashCopy pair 142B:112B successfully created.
```

```
real 0m14.00s
user 0m5.07s
sys 0m0.34s
```

09:10:11 ##### UNFREEZE FLASH - FCS\_B\_TO\_C\_VOLS.

Date/Time: April 20, 2005 9:10:14 AM CDT IBM DSCLI Version: 5.0.3.13  
DS: IBM.2107-7510621

```
CMUC00172I unfreezeflash: FlashCopy consistency group for logical
subsystem 14: successfully reset.
```

```
real 0m13.14s
user 0m4.68s
sys 0m0.31s
```

09:10:24 ##### LIST PPRC - PPRC\_A\_to\_B.

Date/Time: April 20, 2005 9:10:27 AM CDT IBM DSCLI Version: 5.0.3.13  
DS: IBM.2107-7505831

```
CMUC00149I mkpprcpath: Remote Mirror and Copy path 10:14 successfully
established.
```

```
real 0m13.62s
user 0m4.81s
sys 0m0.37s
```



## Split Mirror Backup / Recovery Solution with the IBM TotalStorage DS8000 Series

```
09:10:38 ##### RESUME PPRC - PPRC_A_to_B.  
Date/Time: April 20, 2005 9:10:40 AM CDT IBM DSCLI Version: 5.0.3.13  
DS: IBM.2107-7505831  
CMUC00158I resumepprc: Remote Mirror and Copy volume pair 1051:141F  
relationship successfully resumed. This message is being returned  
before the copy completes.  
CMUC00158I resumepprc: Remote Mirror and Copy volume pair 100C:1418  
relationship successfully resumed. This message is being returned  
before the copy completes.  
CMUC00158I resumepprc: Remote Mirror and Copy volume pair 100D:1419  
relationship successfully resumed. This message is being returned  
before the copy completes.  
CMUC00158I resumepprc: Remote Mirror and Copy volume pair 100E:141A  
relationship successfully resumed. This message is being returned  
before the copy completes.  
CMUC00158I resumepprc: Remote Mirror and Copy volume pair 100F:141B  
relationship successfully resumed. This message is being returned  
before the copy completes.  
CMUC00158I resumepprc: Remote Mirror and Copy volume pair 1010:141C  
relationship successfully resumed. This message is being returned  
before the copy completes.  
CMUC00158I resumepprc: Remote Mirror and Copy volume pair 1011:141D  
relationship successfully resumed. This message is being returned  
before the copy completes.  
CMUC00158I resumepprc: Remote Mirror and Copy volume pair 1012:141E  
relationship successfully resumed. This message is being returned  
before the copy completes.  
CMUC00158I resumepprc: Remote Mirror and Copy volume pair 101B:1408  
relationship successfully resumed. This message is being returned  
before the copy completes.  
CMUC00158I resumepprc: Remote Mirror and Copy volume pair 101C:1409  
relationship successfully resumed. This message is being returned  
before the copy completes.  
CMUC00158I resumepprc: Remote Mirror and Copy volume pair 101D:140A  
relationship successfully resumed. This message is being returned  
before the copy completes.  
CMUC00158I resumepprc: Remote Mirror and Copy volume pair 101E:140B  
relationship successfully resumed. This message is being returned  
before the copy completes.  
CMUC00158I resumepprc: Remote Mirror and Copy volume pair 101F:140C  
relationship successfully resumed. This message is being returned  
before the copy completes.  
CMUC00158I resumepprc: Remote Mirror and Copy volume pair 1020:140D  
relationship successfully resumed. This message is being returned  
before the copy completes.  
CMUC00158I resumepprc: Remote Mirror and Copy volume pair 1021:140E  
relationship successfully resumed. This message is being returned  
before the copy completes.  
CMUC00158I resumepprc: Remote Mirror and Copy volume pair 1022:140F  
relationship successfully resumed. This message is being returned  
before the copy completes.  
CMUC00158I resumepprc: Remote Mirror and Copy volume pair 1045:1436  
relationship successfully resumed. This message is being returned  
before the copy completes.
```



## Split Mirror Backup / Recovery Solution with the IBM TotalStorage DS8000 Series

CMUC00158I resumepprc: Remote Mirror and Copy volume pair 1046:1437 relationship successfully resumed. This message is being returned before the copy completes.  
CMUC00158I resumepprc: Remote Mirror and Copy volume pair 1047:1438 relationship successfully resumed. This message is being returned before the copy completes.  
CMUC00158I resumepprc: Remote Mirror and Copy volume pair 1048:1439 relationship successfully resumed. This message is being returned before the copy completes.  
CMUC00158I resumepprc: Remote Mirror and Copy volume pair 1049:143A relationship successfully resumed. This message is being returned before the copy completes.  
CMUC00158I resumepprc: Remote Mirror and Copy volume pair 104A:143B relationship successfully resumed. This message is being returned before the copy completes.  
CMUC00158I resumepprc: Remote Mirror and Copy volume pair 102B:1426 relationship successfully resumed. This message is being returned before the copy completes.  
CMUC00158I resumepprc: Remote Mirror and Copy volume pair 102C:1427 relationship successfully resumed. This message is being returned before the copy completes.  
CMUC00158I resumepprc: Remote Mirror and Copy volume pair 102D:1428 relationship successfully resumed. This message is being returned before the copy completes.  
CMUC00158I resumepprc: Remote Mirror and Copy volume pair 102E:1429 relationship successfully resumed. This message is being returned before the copy completes.  
CMUC00158I resumepprc: Remote Mirror and Copy volume pair 1037:142E relationship successfully resumed. This message is being returned before the copy completes.  
CMUC00158I resumepprc: Remote Mirror and Copy volume pair 1038:142F relationship successfully resumed. This message is being returned before the copy completes.  
CMUC00158I resumepprc: Remote Mirror and Copy volume pair 1088:1440 relationship successfully resumed. This message is being returned before the copy completes.  
CMUC00158I resumepprc: Remote Mirror and Copy volume pair 1089:1441 relationship successfully resumed. This message is being returned before the copy completes.  
CMUC00158I resumepprc: Remote Mirror and Copy volume pair 102F:142A relationship successfully resumed. This message is being returned before the copy completes.  
CMUC00158I resumepprc: Remote Mirror and Copy volume pair 1030:142B relationship successfully resumed. This message is being returned before the copy completes.

real 0m14.56s

user 0m5.53s

sys 0m0.35s

09:10:52 ##### LIST PPRC - PPRC\_A\_TO\_B\_VOLS\_ARCH - check Full Duplex.

09:11:24 ##### List PPRC - PPRC\_A\_TO\_B\_VOLS\_ARCH - not all luns are in Full Duplex state.

09:11:41 ##### List PPRC - PPRC\_A\_TO\_B\_VOLS\_ARCH - not all luns are in Full Duplex state.



## Split Mirror Backup / Recovery Solution with the IBM TotalStorage DS8000 Series

```
09:11:58 ##### List PPRC - PPRC_A_TO_B_VOLS_ARCH - not all luns
are in Full Duplex state.
09:12:16 ##### List PPRC - PPRC_A_TO_B_VOLS_ARCH - not all luns
are in Full Duplex state.
09:12:32 ##### List PPRC - PPRC_A_TO_B_VOLS_ARCH - not all luns
are in Full Duplex state.
09:12:50 ##### List PPRC - PPRC_A_TO_B_VOLS_ARCH - not all luns
are in Full Duplex state.
09:13:07 ##### List PPRC - PPRC_A_TO_B_VOLS_ARCH - not all luns
are in Full Duplex state.
09:13:24 ##### List PPRC - PPRC_A_TO_B_VOLS_ARCH - not all luns
are in Full Duplex state.
09:13:24 ##### RESYNCFLASH - FCS_B_TO_C_VOLS_ARCH.
Date/Time: April 20, 2005 9:13:27 AM CDT IBM DSCLI Version: 5.0.3.13
DS: IBM.2107-7510621
CMUC00168I resyncflash: FlashCopy volume pair 142A:112A successfully
resynched.
CMUC00168I resyncflash: FlashCopy volume pair 142B:112B successfully
resynched.

real  0m21.79s
user  0m4.77s
sys   0m0.39s
#####
09:13:46 DSCLI - PPRC STEPS - COMPLETED ON SOURCE
#####
```



## References

- 1) IBM TotalStorage DS8000 Series: Concepts and Architecture - IBM Document Number: SG24-6452-00 <http://www.redbooks.ibm.com/>
- 2) IBM Enterprise Storage Server - IBM Document Number: SG24-5465-00 <http://www.redbooks.ibm.com/>
- 3) ESS Layout Considerations for a Heterogeneous System Landscape - Dr. Jens Claussen, SAP Advanced Technology Group, December 2000 [Presentation]
- 4) SAP R/3 Storage Management - Split Mirror Backup Recovery on IBM's Enterprise Storage Server (ESS) - Siegfried Schmidt, SAP AG, Advanced Technology Group, February 2000, <http://service.sap.com/split-mirror> or <http://www.storage.ibm.com/hardsoft/diskdrls/technology.htm>
- 5) Fundamentals of Database Layout SAP AG, Version 2.0 August 2000 <http://service.sap.com/atg> -> DB & Storage Layouts
- 6) Oracle 8i Backup & Recovery Handbook - Rama Velpuri and Anand Adkoli, Oracle Press, Osborne McGraw Hill, 2001
- 7) SSQJ Documentation Version 9.B – SAP Advanced Technology Group. <http://service.sap.com/atg>
- 8) Storage Management for SAP and DB2 UDB: Split Mirror Backup / Recovery With IBM's Enterprise Storage Server (ESS) - Sanjoy Das, Siegfried Schmidt, Jens Claussen, BalaSanni Godavari, August 2001, <http://service.sap.com/split-mirror> or <http://www.storage.ibm.com/hardsoft/diskdrls/technology.htm>
- 9) Storage Management for SAP and Oracle: Split Mirror Backup / Recovery With IBM's Enterprise Storage Server (ESS) - Sanjoy Das, Siegfried Schmidt, Peter Pitterling, BalaSanni Godavari, October 2001 <http://service.sap.com/split-mirror> or [www.storage.ibm.com/hardsoft/products/sap/splitmirror-oracle.pdf](http://www.storage.ibm.com/hardsoft/products/sap/splitmirror-oracle.pdf)
- 10) Storage Management for SAP and Oracle8i on SUN SOLARIS: Split Mirror Backup / Recovery With IBM's Enterprise Storage Server (ESS) - Sanjoy Das, Siegfried Schmidt, Sathees Kodi, Bala Sanni Godavari, June, 2002, <http://service.sap.com/split-mirror>