

Memo To: IBM Suppliers

Ref: [EU Battery Directive 2006/66/EC](#)

http://eur-lex.europa.eu/LexUriServ/site/en/oj/2006/l_266/l_26620060926en00010014.pdf

Abstract:

EU Battery Directive 2006/66/EC and corresponding EU country legislation mandates all batteries to be marked with the crossed out wheeled bin. This applies to all batteries imported into the EU on or after **September 26, 2008**. For batteries that are too small to apply this marking, the marking must be placed on the outer package of the battery or the packaging of the product that contains the battery.

In order to not confuse the crossed out wheeled bin symbol as referring to the packaging material, and also to clearly identify the geography it applies to, the supplemental wording 'Batteries' and 'Europe Only' must be added as shown in figure 2 below when the symbol is applied to the outer packaging.

The picture below shows the crossed out wheeled bin symbol in the proper proportion.

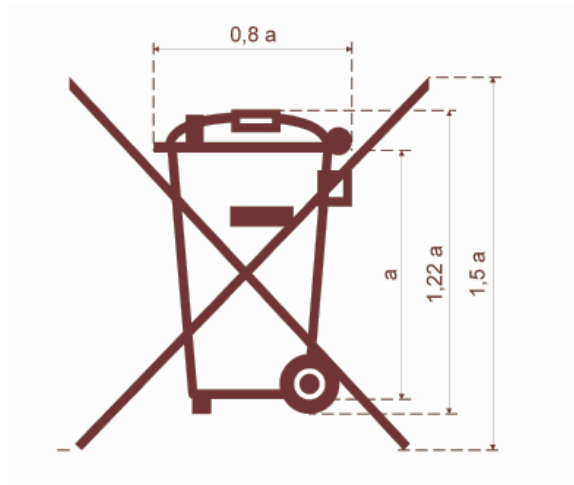

Figure 1: dimensions of wheeled bin symbol

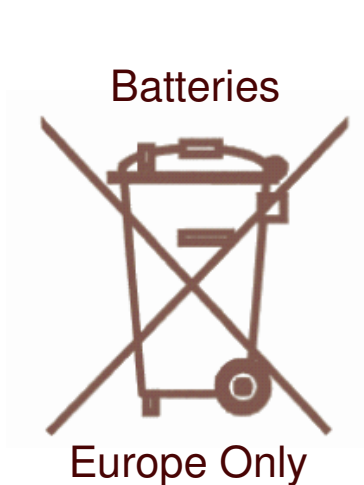

Figure 2: wheeled bin symbol with supplements

Note: the EU battery directive requirements can be found in IBM engineering spec 46G3772.

Summary of Requirements:

Since many IBM products contain button cell batteries that are too small to mark per the above requirement, IBM is implementing the following strategy to ensure that we meet the legal requirements to import batteries and products containing batteries into the EU after **September 26, 2008**.

All outer packaging of batteries and products containing batteries must be marked with the crossed out wheeled bin as shown in figure 2. There are 3 options to comply listed in order of preference:

- 1) print/show the symbol on the product package label
- 2) preprint the symbol on the outer container or carton
- 3) apply a separate label with the symbol to the outer container or carton.

Examples are shown in the table at the end of this letter

To support the implementation of these requirements, the Global Labeling Guides have been updated accordingly.

Volume 2 (product package labels) now requires the crossed out wheeled bin symbol to be shown on product package labels for finished goods products.

Volume 6 (Field Replaceable Unit (FRU) package labels) now requires the crossed out wheeled bin symbol to be shown on FRU package labels of FRUs that are a battery or contain a battery.

Volume 8 (Symbols and special labels) gives an overview of the crossed out wheeled bin symbol and provides references to drawings and related specifications.

The following table gives an overview of how items need to be marked or labelled:

Item Type	Marking / Label Required	Reference to Global Labeling Guide Vol.
Finished goods – Systems (all)	YES	2
MES containing batteries	YES	2
MES w/o batteries	NO	2
Options containing batteries	YES	2
Options w/o batteries	NO	2
FRUs - Batteries	YES	6
FRUs containing batteries	YES	6
FRUs w/o batteries	NO	6

*) FRU – Field Replaceable Unit

MES – Miscellaneous Equipment Specification (= additional, complementary features)

References:

P/N 46G3772 : IBM Engineering Specification - Baseline Environmental Requirements for Supplier Deliverables to IBM

P/N 5897661 : Recyclable Packaging Materials – Selection and Identification

P/N 31L5039 : Global Labeling Guide Volume 2 – Product Package Labels

P/N 31L5241 : Global Labeling Guide Volume 6 – FRU Package Labels

P/N 36P3127 : Global Labeling Guide Volume 8 – Symbols and Special Labels

All of the above specifications are accessible via the IBM Global Procurement portal at

<http://www-03.ibm.com/procurement/proweb.nsf/ContentDocsByTitle/United+States~Information+for+suppliers>

The current target date for implementation of the above requirements is September 26, 2008 per EU directive 2006/66/EC.

Suppliers : for questions please contact your IBM Global Procurement representative.

Examples of methods to apply the crossed-out wheeled bin symbol to product packages

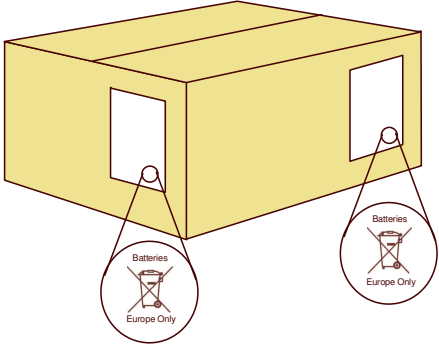
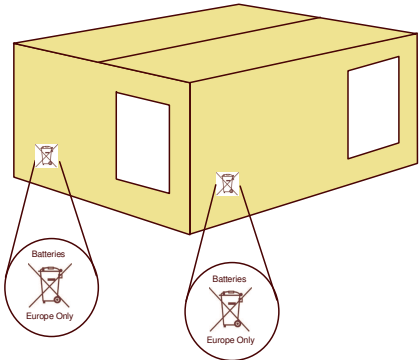
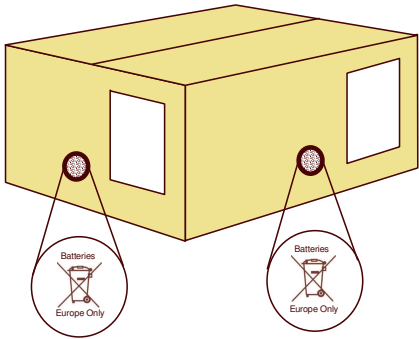
<p>Preferred</p> <p>Printed on the product package label</p>	 <p>The diagram shows a yellow cardboard box with two labels on its front face. Each label contains the crossed-out wheeled bin symbol, which includes the word 'Batteries' above the symbol and 'Europe Only' below it. Lines connect the labels to the symbols.</p>
<p>Acceptable</p> <p>Pre-printed on the carton surface</p>	 <p>The diagram shows a yellow cardboard box with two rectangular cutouts on its front face. The crossed-out wheeled bin symbol, including the words 'Batteries' and 'Europe Only', is pre-printed on the surface of the box, centered over each cutout. Lines connect the symbols to the cutouts.</p>
<p>Last resort</p> <p>Separate label showing the symbol</p>	 <p>The diagram shows a yellow cardboard box with two rectangular cutouts on its front face. Two separate circular labels are attached to the box, one centered over each cutout. Each label contains the crossed-out wheeled bin symbol, including the words 'Batteries' and 'Europe Only'. Lines connect the labels to the cutouts.</p>

Note:

for each of these packaging applications, the minimum size of the symbol itself (excluding words) must be 10mm x 10mm.

End of Document